

***Ultra II* COMPUTERIZED DEMAND with high-flow 1" valve**

North Star[®]

AUTOMATIC WATER CONDITIONERS

NSCA39UD - NSTA60UD

Installation • • Operation • • Maintenance
• • Repair Parts • •

**IF YOU HAVE QUESTIONS WHEN INSTALLING,
OPERATING AND MAINTAINING YOUR CONDITIONER,
OR WHEN SETTING THE TIMER. . .**

**CALL TOLL FREE
1 - 800 - 972 - 0135**

**To register your name and water conditioner for the
ESP transmissions feature, please see page 23.**

★NORTHSTAR AUTOMATIC WATER CONDITIONER

WARRANTY



TEN YEAR LIMITED WARRANTY GENERAL CONDITIONS

Damage to any part of this water conditioner because of misuse, misapplication, neglect, alteration, accident, installation or operation contrary to our printed instructions, or damage caused by any unusual force of nature such as, but not limited to, freezing, flood, hurricane, tornado, or earthquake is not covered by this warranty. In all such cases, regular parts and service charges will apply.

We assume no warranty liability in connection with this water conditioner other than specified herein. This warranty is in lieu of all other warranties, expressed or implied, including warranties of fitness for a particular purpose. We do not authorize any person or representative to assume for us any other obligations on the sale of this water conditioner.

Should a defect or malfunction occur, contact your contractor. If you are unable to contact your contractor, return the part, freight prepaid, directly to the factory at the address below. Enclose with the part a full description of the problem, with your name, full address, date purchased, model and serial numbers, and selling contractor's name and address. We will repair or replace the part and return it to you at no cost if our repair department determines it to be defective under the terms of the warranty.

This warranty gives you specific legal rights and you may have other rights which vary from state to state.

This water conditioner is manufactured by North Star Water conditioning, PO Box 64310, St. Paul, MN 55164-4310; customer information telephone no. 1-800-972-0135.

WARRANTY POLICY

North Star Water Conditioning, St. Paul, MN, warrants this water conditioner as stated herein:

From the date of installation, within the warranty period described below, we will repair or replace any part which we find defective because of faulty materials and workmanship, or corrosion. You pay only freight to our factory and local labor charges.

* ONE YEAR ON COMPLETE UNIT

*THREE YEARS ON ELECTRONIC CONTROL * THREE YEARS ON CONTROL VALVE BODY

* FIVE YEARS ON SALT STORAGE TANK * TEN YEARS ON MINERAL TANK, EXCLUDING MINERAL



SAFETY GUIDES

FOLLOW THE INSTALLATION INSTRUCTIONS CAREFULLY. FAILURE TO INSTALL THE SOFTENER PROPERLY VOIDS THE WARRANTY.

BEFORE YOU BEGIN INSTALLATION, READ THIS ENTIRE MANUAL. THEN, OBTAIN ALL THE MATERIALS AND TOOLS YOU WILL NEED TO MAKE THE INSTALLATION.

CHECK LOCAL PLUMBING AND ELECTRICAL CODES. THE INSTALLATION MUST CONFORM TO THEM. CODES IN THE STATE OF MASSACHUSETTS REQUIRE INSTALLATION BY A LICENSED PLUMBER. FOR INSTALLATION, USE PLUMBING CODE 248-CMR OF THE COMMONWEALTH OF MASSACHUSETTS.

USE ONLY LEAD-FREE SOLDER AND FLUX FOR ALL SWEAT-SOLDER CONNECTIONS, AS REQUIRED BY STATE AND FEDERAL CODES.

USE CARE WHEN HANDLING THE SOFTENER. DO NOT TURN UPSIDE DOWN, DROP, OR SET ON SHARP PROTRUSIONS.

DO NOT LOCATE THE SOFTENER WHERE FREEZING TEMPERATURES OCCUR. DO NOT ATTEMPT TO TREAT WATER OVER 120°F. **FREEZING, OR HOT WATER DAMAGE VOIDS THE WARRANTY.**

AVOID INSTALLING IN DIRECT SUNLIGHT. EXCESSIVE SUN HEAT MAY CAUSE DISTORTION OR OTHER DAMAGE TO NON-METALLIC PARTS.

THE SOFTENER REQUIRES A MINIMUM WATER FLOW OF 3 GALLONS PER MINUTE AT THE INLET. **MAXIMUM ALLOWABLE INLET WATER PRESSURE IS 125 PSI.** IF DAYTIME PRESSURE IS OVER 80 PSI, NIGHTTIME PRESSURE MAY EXCEED THE MAXIMUM. USE A PRESSURE REDUCING VALVE IF NECESSARY. (ADDING A PRESSURE REDUCING VALVE MAY REDUCE THE FLOW.)

THE SOFTENER WORKS ON 24 VOLT-60 Hz ELECTRICAL POWER ONLY. BE SURE TO USE THE INCLUDED TRANSFORMER AND PLUG IT INTO A NOMINAL 120V, 60 CYCLE HOUSEHOLD OUTLET THAT IS GROUNDED AND PROPERLY PROTECTED BY AN OVER CURRENT DEVICE SUCH AS A CIRCUIT BREAKER OR FUSE. IF TRANSFORMER IS REPLACED, USE ONLY THE AUTHORIZED SERVICE, CLASS II, 24 VOLT, 10VA TRANSFORMER.

THIS SYSTEM IS NOT INTENDED TO BE USED FOR TREATING WATER THAT IS MICROBIOLOGICALLY UNSAFE OF UNKNOWN QUALITY WITHOUT ADEQUATE DISINFECTION BEFORE OR AFTER THEY SYSTEM.

UNPACKING / INSPECTION

The softener is shipped in one carton (NSCA models) or two cartons (NSTA models). It is completely assembled at the factory, except as required at installation.

Be sure to check the entire softener for any shipping damage or parts loss. Also note damage to the shipping cartons. Contact the transportation company

for all damage and loss claims. *The manufacturer is not responsible for damages in transit.*

Small parts, needed to install the softener, are on a skin packed cardboard piece. To avoid loss of the small parts, keep them on the skin pack until you are ready to use them.

TABLE OF CONTENTS

	PAGE NO.
WARRANTY, SAFETY GUIDES	2
SPECIFICATIONS, DIMENSIONS	4
BEFORE STARTING INSTALLATION	5
TYPICAL INSTALLATION ILLUSTRATION	6
INSTALLATION STEPS	7 - 10
PROGRAMMING THE <i>Ultra II</i> DEMAND TIMER	10 -11
SANITIZING PROCEDURES	12
WATER AND WATER CONDITIONING	13 - 14
HOW THE WATER SOFTENER WORKS	14 - 15
GENERAL WATER SOFTENER MAINTENANCE	16 - 17
<i>Ultra II</i> DEMAND TIMER FEATURES, SETTINGS, AND SERVICE	
TIMER DISPLAYS / OPTIONAL RECHARGE CONTROLS	18 - 19
PROGRAM MEMORY, RECHARGE (START) TIME, HEAVY DUTY BACKWASH ...	20
MODEL CODE, 12 OR 24 HOUR CLOCK, GALLONS OR LITERS MEASURE, AUTOMATIC ELECTRONIC DIAGNOSTICS	21
ELECTRONIC SYSTEM PROFILE	22 - 23
SERVICE CHECKOUT PROCEDURES, WIRING SCHEMATIC	24 - 25
WATER FLOW THROUGH VALVE	26
REPAIR PARTS	28 - 31
PARTS RETURN TAGS	32

★NORTHSTAR AUTOMATIC WATER CONDITIONER

SPECIFICATIONS / DIMENSIONS

	MODEL NSCA39UD	MODEL NSTA60UD
RATED CAPACITY	See Rating Decal, Located On The Softener	
RATED EFFICIENCY ①	See Rating Decal, Located On The Softener	
AMOUNT OF HIGH CAPACITY RESIN (lbs / cu ft)	52 / 1.0	100 / 1.9
RESIN TANK NOMINAL SIZE (in., dia x height)	9 x 40	12 x 54
SERVICE FLOW RATE (gpm)	See Rating Decal, Located On The Softener	
PRESSURE DROP AT SERVICE FLOW	See Rating Decal, Located On The Softener	
WATER SUPPLY MAXIMUM HARDNESS (gpg) ②	110	120
WATER SUPPLY MAX. CLEAR WATER IRON (ppm) ②	8	10
WATER PRESSURE LIMITS (min. / max. psi)	20 – 125	
WATER TEMPERATURE LIMITS (°F)	40 – 120	
WATER SUPPLY MINIMUM FLOW RATE (gpm)	3	
REGENERATION CYCLE FLOW RATES (gpm)		
FILL (flow to brine tank)	.3	.3
BRINING	.15	.31
BRINE RINSE	.10	.22
BACKWASH	2.0	3.0
FAST RINSE	2.0	3.0

These systems conform to NSF/ANSI 44 for specific performance claims as verified and substantiated by test data.

① Efficiency rating is only valid at the lowest salt dosage. These softeners were efficiency rated according to NSF/ANSI Standard 44.

② Determined by water analysis from a qualified water testing laboratory.

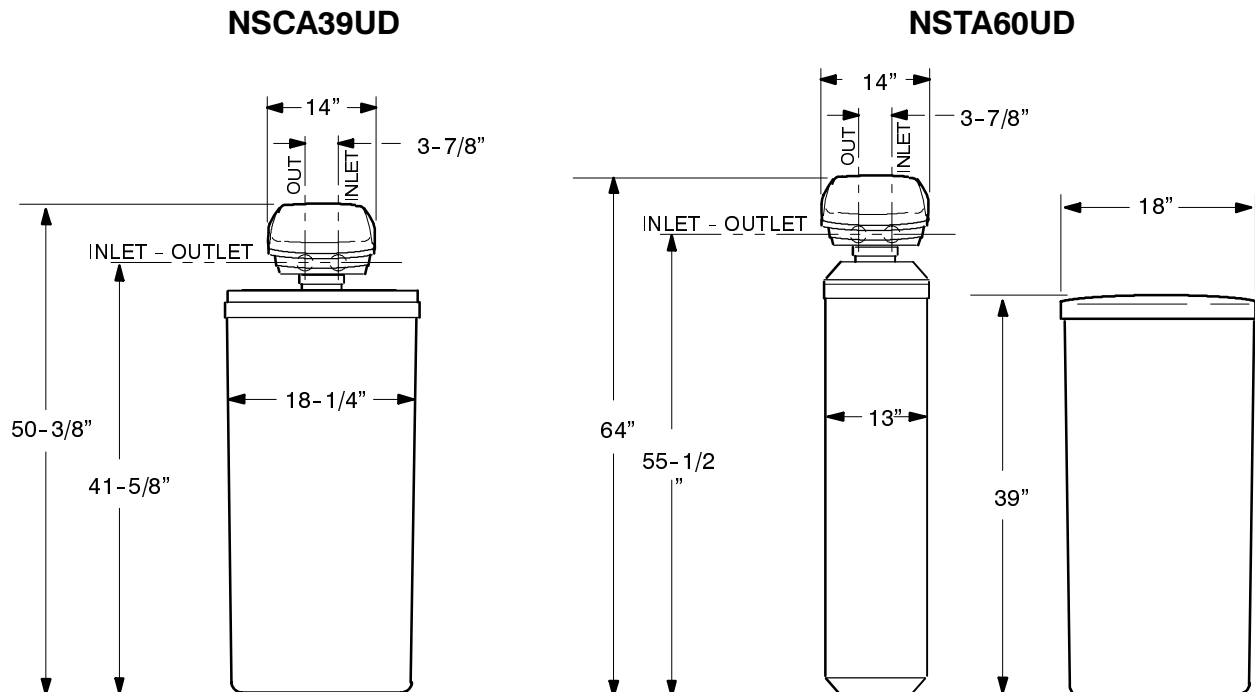

BEFORE STARTING INSTALLATION

► **WHERE TO INSTALL THE SOFTENER**

- Place the softener as close as possible to the pressure tank (well system) or water meter (city water).
- Place the softener as close as possible to a floor drain, or other acceptable drain point (laundry tub, sump, standpipe, etc.).
- Connect the softener to the main water supply pipe BEFORE or AHEAD OF the water heater. **DO NOT RUN HOT WATER THROUGH THE SOFTENER.** Temperature of water passing through the softener must be less than 120°F (49°C).
- Keep outside faucets on hard water to save soft water and salt.
- Do not install the softener in a place where it could freeze. **Damage caused by freezing is not covered by the warranty.**
- Put the softener in a place water damage is least likely to occur if a leak develops. The manufacturer will not repair or pay for water damage.
- A 120 volt electric outlet, to plug the included transformer into, is needed within 10 feet of the softener. The transformer has an attached 10 foot power cable. **Be sure the electric outlet and transformer are in an inside location, to protect from wet weather.**
- If installing in an outside location, you must take the steps necessary to assure the softener, installation plumbing, wiring, etc., are as well protected from the elements, contamination, vandalism, etc., as when installed indoors.
- **Keep the softener out of direct sunlight.** The sun's heat will melt plastic parts.

► **TOOLS, PIPE and FITTINGS, OTHER MATERIALS YOU WILL NEED (see page 6)**

▪In and out fittings included with the softener are 1" (nominal) copper sweat tubes. To maintain full valve flow, 1" pipes to and from the softener fittings are recommended. You should maintain the same, or larger, pipe size as the water supply pipe, up to the softener inlet and outlet.

▪Use copper, brass, or galvanized pipe and fittings. Some codes may also allow CPVC plastic pipe.

▪ALWAYS install the included bypass valve, or 3 shut-off valves. Bypass valves let you turn off water to the softener for repairs if needed, but still have water in the house pipes.

▪Drain hose (5/8" inside diameter) is needed for the valve drain. See step 5 on page 8. A 15' length of hose is included with some models.

▪A length of 3/8" or 7/16" inside diameter hose is needed for the salt tank drain. A 7' length of hose is included with some models. If a longer length is needed, you can buy good quality, thick-wall, flexible hose at most hardware stores or supply houses.

▪If a rigid valve drain is needed, to comply with plumbing codes, you can buy the parts needed (see page 8) to connect a 1/2 in. copper tubing drain.

▪Nugget or pellet water softener salt is needed to fill the brine tank (see page 9, 10 and 16).

► **PLAN HOW YOU WILL INSTALL THE SOFTENER**

You must first decide how to run in and out pipes to the softener. Look at the house main water pipe at the point where you will connect the softener. Is the pipe soldered copper, glued plastic, or threaded brass/galvanized? What is the pipe size?

Now look at the typical installation illustration on page 6. Use it as a guide when planning your particular installation. **Be sure to direct raw, hard water to the softener valve inlet fitting.** The valve is marked IN and OUT.

★ NORTHSTAR AUTOMATIC WATER CONDITIONER

TYPICAL SOLDERED COPPER or CPVC INSTALLATIONS

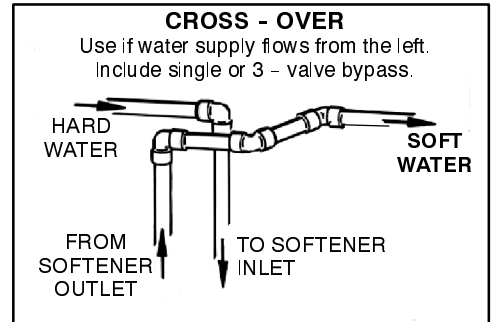
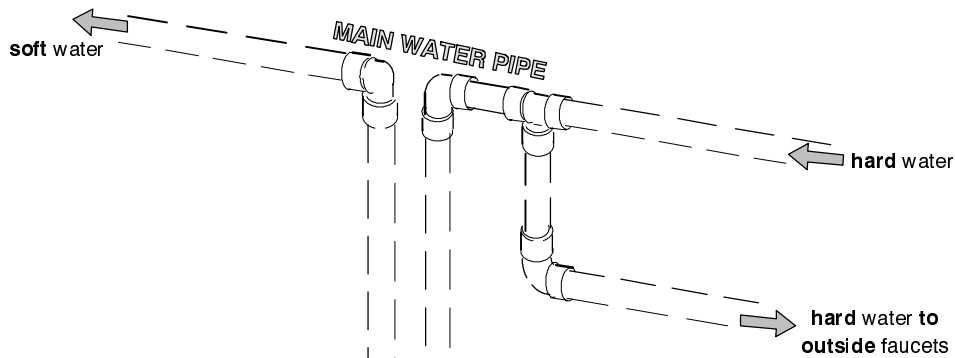

Note: To install with **threaded plumbing**, buy 1" adaptors, either sweat solder or compression, to connect to the 1" copper tubes.

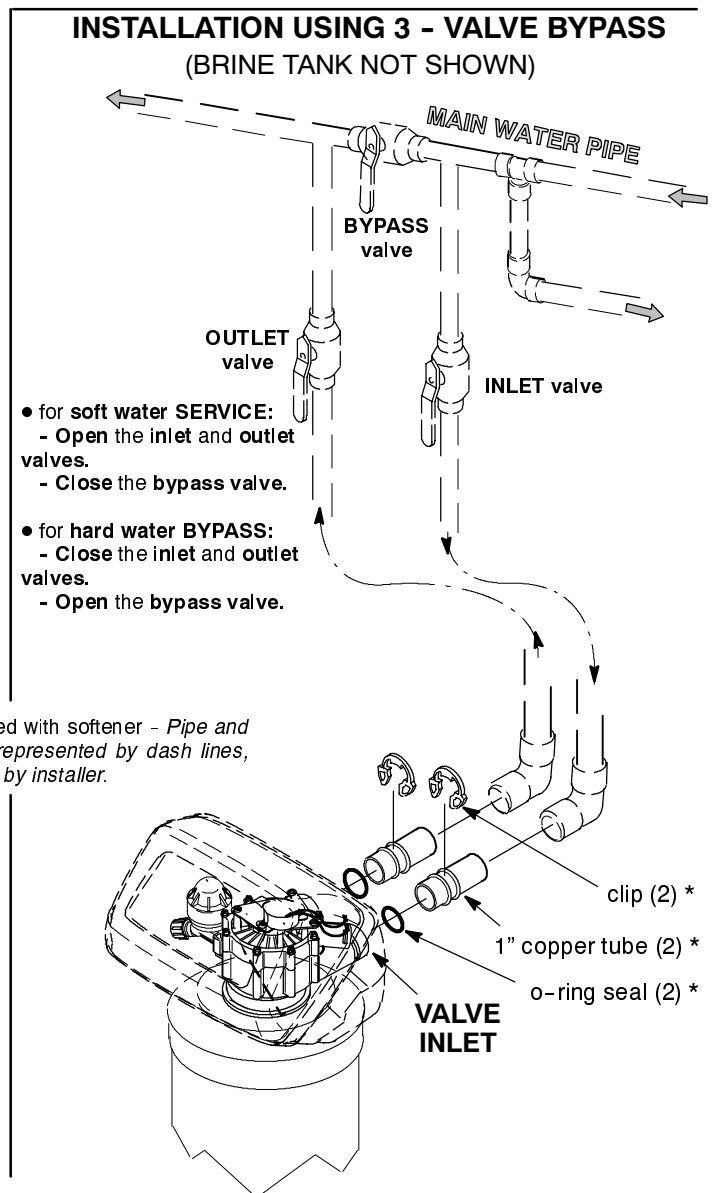
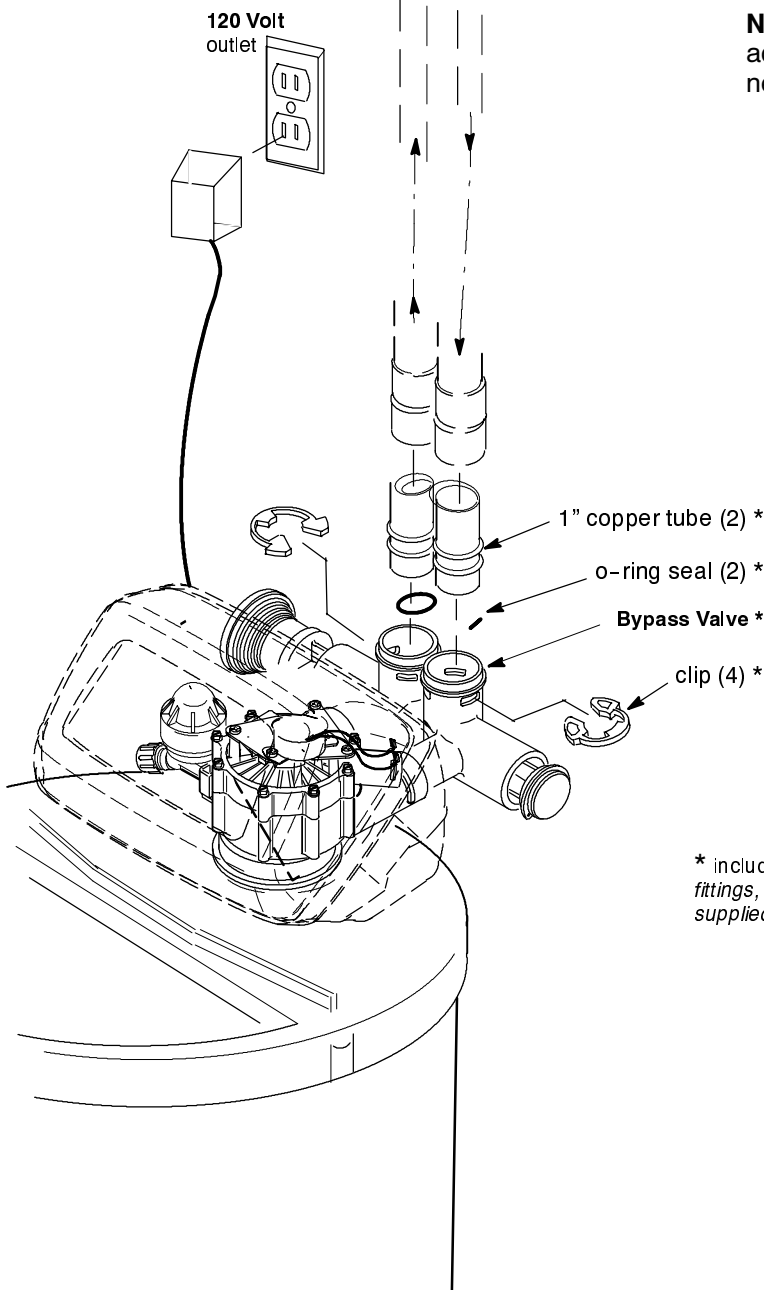

* included with softener - Pipe and fittings, represented by dash lines, supplied by installer.

★NORTHSTAR AUTOMATIC WATER CONDITIONER

INSTALLATION STEPS

1. INSTALL BYPASS VALVE and/or COPPER TUBES:

NOTE: Before installing the copper tubes or bypass valve, be sure the turbine and support are firmly in place, in the valve outlet. Blow into the valve port and observe the turbine for free rotation.

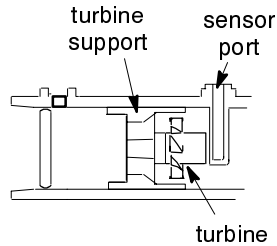

▶ Slide copper tubes, with lubricated o-ring seals in place, into the valve inlet and outlet ports...figure 1A.

- OR -

▶ Push the bypass valve, with lubricated o-ring seals in place, into the valve inlet and outlet ports...figures 1A and 1C.

▶ Snap the 2 large plastic clips in place, from the top, down...figures 1A and 1B. **Be sure they snap into place. Pull on the copper tubes, or bypass valve, to make sure they held securely in place.**

2. INSTALL THE BRINE TANK OVERFLOW FITTINGS:

▶ Insert the rubber grommet into the 3/4" diameter hole in the brine tank sidewall...see page 8.

▶ Push the barbed end of the hose adaptor elbow into the grommet.

3. MOVE THE SOFTENER ASSEMBLY (cabinet models), OR RESIN TANK (2 tank models) INTO INSTALLATION POSITION:

▶ Be sure the installation surface is level and smooth. If needed, place the tank on a section of 3/4" thick (min.) plywood. Then, place shims under the plywood as needed to level the softener.

4. PLUMB IN AND OUT PIPES TO AND FROM SOFTENER:

CAUTIONS: Observe all of the following cautions while you connect inlet and outlet plumbing.

▶ Turn off the house water supply valve and open faucets to relieve pressure in the pipes.

▶ BE SURE RAW, **HARD WATER** IS DIRECTED TO THE VALVE INLET PORT.

FIGURE 1

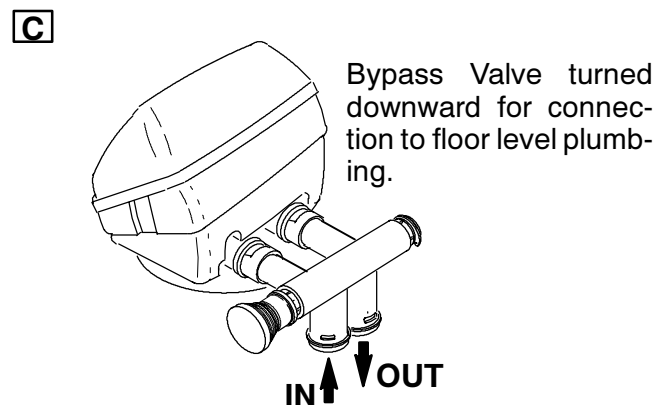
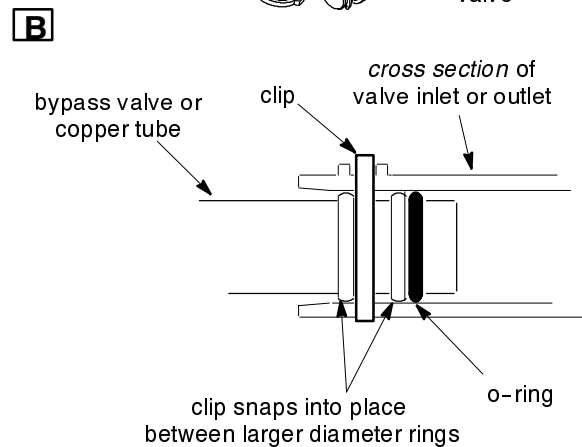
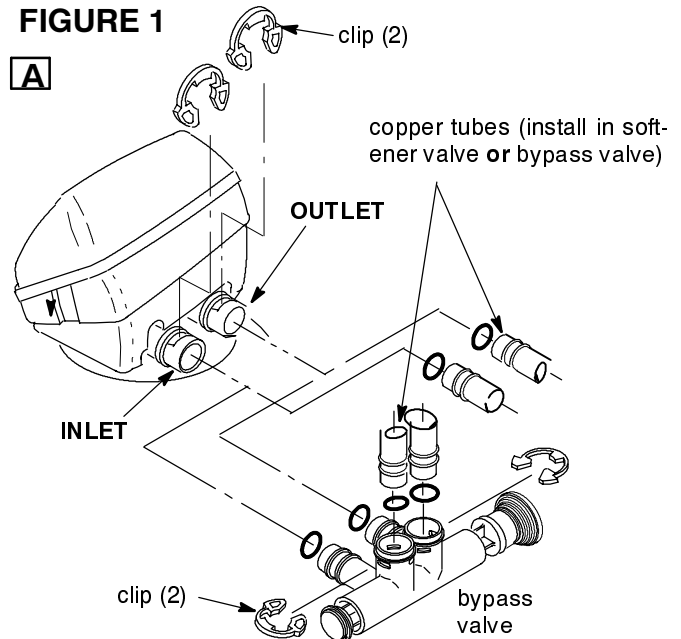

▶ Be sure to use bypass valve(s).

▶ If making a soldered copper installation, **do all sweat soldering before connecting pipes to the softener fittings.** Torch heat will damage plastic parts.

continued

★NORTHSTAR AUTOMATIC WATER CONDITIONER

INSTALLATION STEPS, continued

- ▶ Put grounding clamps (see step 8) on copper tubes before soldering.
- ▶ When turning threaded pipe fittings onto plastic fittings, use care not to cross-thread.
- ▶ Use pipe joint compound on all external pipe threads.
- ▶ Support inlet and outlet plumbing in some manner (use pipe hangers) to keep the weight off of the valve fittings.

5. CONNECT AND RUN THE VALVE DRAIN HOSE:

- ▶ Take a length of 5/8" inside diameter hose and attach to the valve drain fitting.
- ▶ Locate the other end of the hose at a suitable drain point...floor drain, sump, laundry tub, etc. **Check and comply with local codes.**

IMPORTANT: If a longer length of hose is needed, buy and use high quality, thick-wall hose that will not easily kink or collapse. *The water softener will not work if water cannot exit this hose during regenerations.*

- ▶ Tie or wire the hose in place at the drain point. Water pressure will cause it to whip during the back-

wash and fast rinse cycles of regeneration. Also provide an air gap of at least 1-1/2" between the end of the hose and the drain point. An air gap prevents possible siphoning of sewer water, into the softener, if the sewer should "back-up".

- ▶ If raising the drain hose overhead is required to get to the drain point, **do not raise higher than 8' above the floor.** Elevating the hose may cause a back-pressure that could reduce brine draw during regenerations.

6. CONNECT AND RUN THE BRINE TANK OVERFLOW HOSE:

(This drain is for safety only. If the brine tank should over-fill with water, the excess is carried to the drain.)

- ▶ Attach a length of hose (included with some models) to the drain elbow, installed in step 2, page 7. Use a hose clamp to hold it in place.

- ▶ Locate the other end of the hose at the drain point. **Do not elevate** this hose higher than the elbow on the brine tank. **Do not tee** this hose to the valve drain hose.

continued

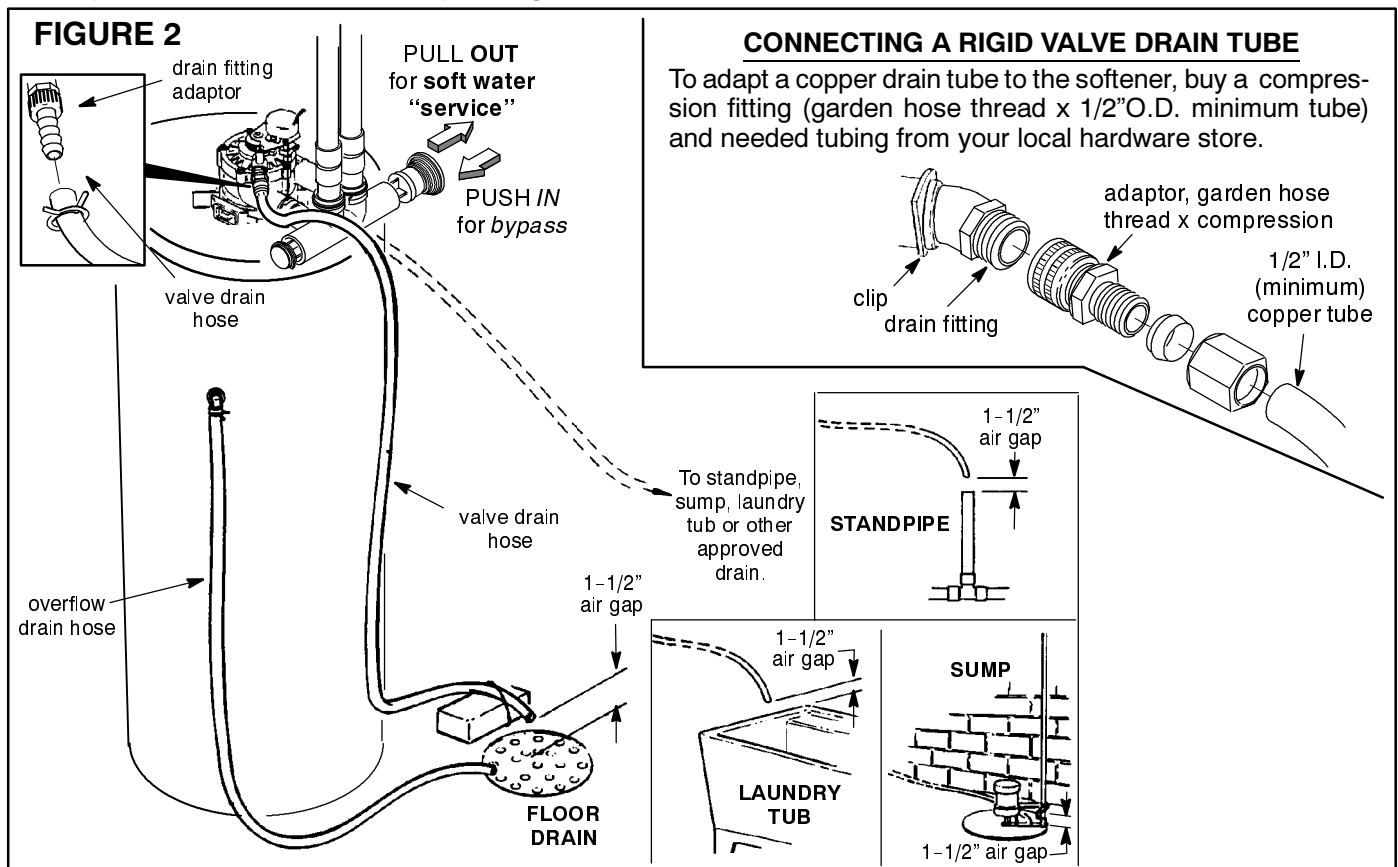

★NORTHSTAR AUTOMATIC WATER CONDITIONER

INSTALLATION STEPS, continued

7. ON TWO TANK MODELS, CONNECT BRINE TUBING:

► Route the brine tubing out, through the largest hole in the brine tank sidewall. Connect the tubing to the nozzle housing, as shown in figure 3, using a nut-ferrule. Tighten the nut, by hand only.

FIGURE 3

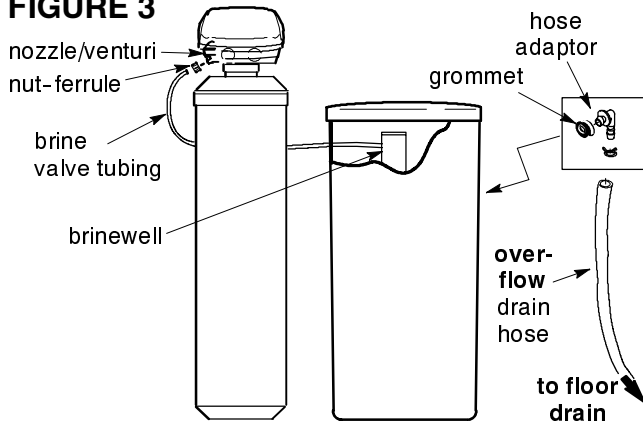

8. INSTALL GROUNDING CLAMPS AND WIRE (IF NEEDED):

► To maintain electrical ground continuity in the house cold water piping, install the included hose clamps and wire as shown. Be sure the pipes are clean, under the clamps, to assure good contact.

FIGURE 4

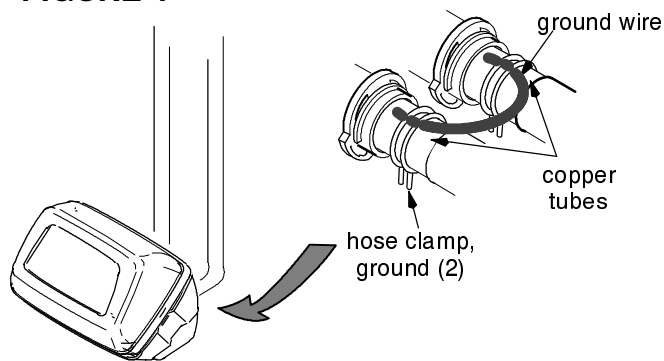

NOTE: A 3-valve bypass system maintains ground continuity.

9. FLUSH PIPES, EXPEL AIR FROM SOFTENER, AND TEST YOUR INSTALLATION FOR WATER LEAKS:

CAUTION: To avoid water or air pressure damage to softener inner parts, be sure to do the following steps exactly as listed.

A. Fully open two cold, **soft** water faucets nearby the softener.

B. Place bypass valve(s) in “**bypass**” position. On a single valve, slide the stem inward to BY-PASS...see page 8. On a 3-valve system, close the inlet and outlet valves, and open the bypass valve...see page 6.

C. Fully open the house main water pipe shutoff valve. Observe a steady flow from both opened faucets.

D. Place bypass valve(s) in “**service**”, **EXACTLY** as follows. **KEEP SOFT WATER FAUCETS OPEN.**

1. SINGLE BYPASS VALVE: **SLOWLY**, pull the valve stem outward to “service”, pausing several times to allow the softener to pressurize slowly.

2. 3-VALVE BYPASS: Fully close the bypass valve and open the outlet valve. **SLOWLY**, open the inlet valve, pausing several times to allow the softener to pressurize slowly.

E. After about three minutes, open a **HOT** water faucet for one minute, or until all air is expelled, then close.

F. Close both cold water faucets.

G. Check your plumbing work for leaks and fix right away, if any are found. *Be sure to observe previous caution notes.*

H. Turn on the gas or electric supply to the water heater. Light the pilot, if applicable.

10. ADD WATER AND SALT TO THE BRINE TANK:

► Remove the salt storage area cover. Add about three gallons of water into the tank. *Do not add into the brinewell.*

continued

★NORTHSTAR AUTOMATIC WATER CONDITIONER

INSTALLATION STEPS, continued

► Fill the tank with NUGGET, PELLET or coarse SOLAR water softener salt. **Do not use** rock, block, granulated, and ice cream making salts, or **salt with iron removing additives**. Also see page 16. *Salt storage capacity* is 200 lbs or more (varies by model).

Note: If the softener is installed in a humid basement or other damp area, it is better to fill the tank with less salt, more frequently (see salt bridging in the maintenance section). Eighty to 100 lbs of salt will last for several months, depending on water hardness, family size, and model of softener.

11. CONNECT TO ELECTRICAL POWER:

► The softener works on 24 volt, 60 Hz electric power. The included transformer changes standard 120 volt AC house power to 24 volts. **Plug the transformer into a 120 volt outlet only.** Be sure the outlet is always “live” so it can not be switched off by mistake.

Plug the transformer into the electrical outlet.

12. PROGRAM THE *Ultra II* DEMAND TIMER, below:

PROGRAMMING THE *Ultra II* DEMAND TIMER

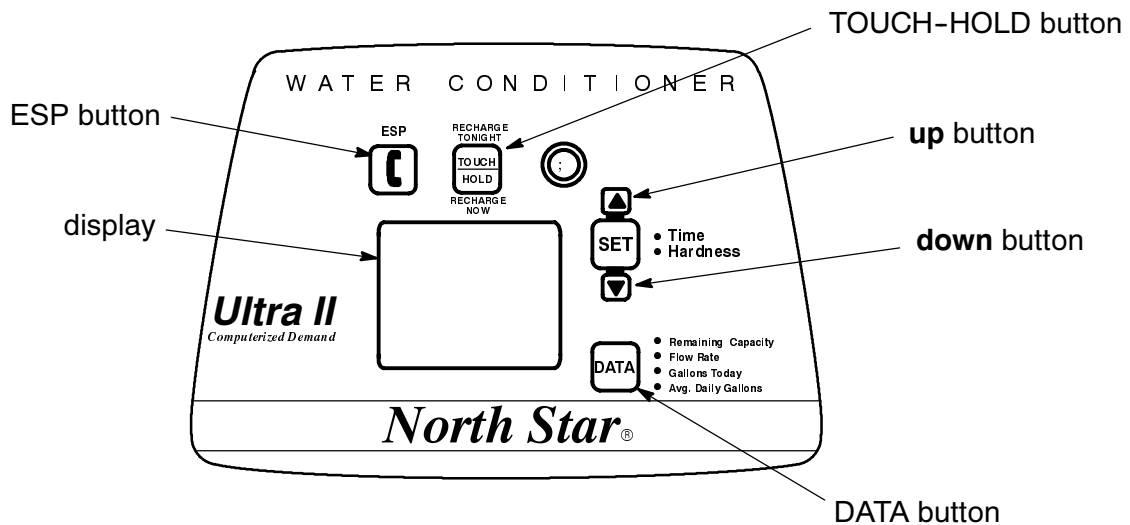

► **TIMER SETTINGS REQUIRED**...upon installation, and after an extended power outage (see Program Memory, page 19).

NOTES:

- WHEN THE TRANSFORMER IS PLUGGED INTO THE ELECTRICAL OUTLET (STEP 11, ABOVE), **12:00AM** (flashing), and **PRESENT TIME** show in the upper display area. Program the timer as instructed on page 11. **If A - - is flashing**, please see Model Code setting on page 20.
- A “beeper” sounds while pressing buttons for timer programming. One beep signals a change in the timer display. Repeated beeps means the timer will not accept a change from the button or arrow you have pressed, and you should use another.
- To program the timer, you will use the SET button.

PROGRAMMING THE *Ultra II* DEMAND TIMER

► SET PRESENT TIME OF DAY

NOTE: If the words PRESENT TIME do not show in the display, press the SET button until they do.

1. Press the SET *button, up or down arrow* to set. The up arrow moves the display ahead; the down arrow moves the time backward.

NOTE: Each press of a SET *button arrow* changes the time by one minute. Holding the arrows in changes the time 32 minutes each second.

2. When the present time shows, press SET to apply.

If the present time is between noon and midnight, be sure PM shows.

If the present time is between midnight and noon, be sure AM shows.



► SET WATER HARDNESS NUMBER

NOTE: If 25 (factory default) and HARDNESS do not show in the display, press the SET button until they do.

1. Press the SET *button, up or down arrow* to set your water hardness number in the display. The down arrow moves the display down to 1. The up arrow moves the display up to 95, 110, or 120, depending on the model code.

NOTE: Each press of a SET *button arrow* changes the display by 1 between 1 and 25. Above 25, the display changes 5 at a time ... 25, 30, 35, etc. Holding an arrow in changes the numbers twice each second.

2. When your water hardness number shows, press SET to apply.

You can get the grains per gallon (gpg) hardness of your water supply from a water analysis laboratory, or call and ask your local water department, if you are on a municipal supply.

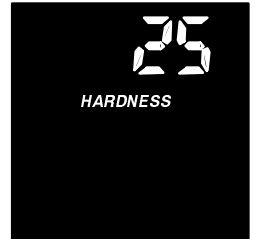

The special *features* of your timer are explained on pages 18, 19, 20 and 21.

TO COMPLETE THE INSTALLATION, DO THE SANITIZING PROCEDURES, PAGE 12.

SANITIZING PROCEDURES

Care is taken at the factory to keep your water softener clean and sanitary. Materials used to make the softener will not infect or contaminate your water supply, and will not cause bacteria to form or grow. However, during shipping, storage, installing and operating, bacteria could get into the softener. For this reason, sanitizing as follows is suggested when installing.

1. Be sure to complete all installation steps, including timer programming.
2. Pour about 3/4 oz of common 5.25% household

bleach (Clorox, Linco, Bo Peep, White Sail, Eagle, etc.) **into the brinewell** (figure 3, page 9).

3. Use the REGENERATE, OR RECHARGE, NOW feature, on the timer, to start an immediate regeneration. The bleach is drawn into and through the water softener to sanitize it. This sanitizing regeneration is over in about two hours. Then, **soft water** is available for your use.

§NOTE: Sanitizing is recommended by the Water Quality Association for disinfecting. On some water supplies, they suggest periodic sanitizing.

NOTE: When the above sanitizing regeneration is over, all remaining bleach is flushed from the conditioner and your house COLD water supply is fully soft immediately. However, **your water heater is filled with hard water** and, as hot water is used, it will refill with soft water. When all the hard water is replaced, in the water heater, hot only, and mixed hot and cold water will be fully soft. If you want totally soft water immediately, after the above regeneration, drain the water heater until the water runs cold. **If you do drain the water heater, use extreme care as the hot water could cause severe burns.**

WATER AND WATER CONDITIONING

WATER

Man's very existence depends on water. It is one of the basic commodities of life. Water is best as nature provides it, is a common misconception. Practically all natural water needs refinement or treatment to make it safe to drink or more satisfactory to use.

The earth's water supply cycle starts in the upper cloud layers. As it falls to the earth as rain or snow, it picks up impurities and gases from the atmosphere. Landing on earth, it seeps over and through the ground, dissolving earth minerals. Passing through limestone, it dissolves calcium and magnesium, the hardness minerals. Iron deposits impart iron to the water. Acidity and sediments are other water conditions.

Municipal water supplies come from surface reservoirs, such as lakes and rivers, or from underground reservoirs. Usually, municipalities chlorinate the water to make it safe to drink. Sediment is removed by filtration. Tastes and odors are reduced or eliminated. The water is conditioned to comply with certain specifications. However, hardness minerals, tastes and odors are not always reduced to the most desirable levels.

Underground reservoirs provide our private water supplies. Because the water is raw and untreated, it can have varying amounts of hardness, iron, tastes, odors, acidity, or combinations of these. Different localities and water levels affect mineral content.

WATER CONDITIONING

Water conditioning is the treatment of four general conditions. These are: *Hardness, Iron, Acidity, Sediments.*

HARDNESS is a term to describe the presence of calcium and magnesium minerals in water. A chemical analysis accurately measures the amount of minerals in grain weight. For example, one gallon of water with five grains per gallon (gpg) hardness has dissolved minerals, that if solidified, about equals the size of one ordinary aspirin tablet. One gallon of water, 25 gpg hard, has a mineral content equal in size to 5 aspirin tablets. Water hardness varies greatly across the country. It generally contains from 3 to 100 gpg.

Hard water affects living in general. Hardness minerals combine with soap to make a soap curd. The curd greatly reduces the cleaning action of soap. Precipitated hardness minerals form a crust on cooking utensils, appliances, and plumbing fixtures. Even the tastes of foods are affected. A water softener removes the hardness minerals to eliminate these problems, and others.

Sodium Information: Water softeners using sodium chloride (salt) for regeneration add sodium to the water. Persons on sodium restricted diets should consider the added sodium as part of their overall intake.

IRON in water is measured in parts per million (ppm). The total* ppm of iron, and type or types*, is determined by chemical analysis. Four different types of iron in water are: ① Ferrous (clear water), ② Ferric (red water), ③ Bacterial and organically bound iron, ④ Colloidal and inorganically bound iron (ferrous or ferric).

*Water may contain one or more of the four types of iron and any combination of these. Total iron is the sum of the contents.

① Ferrous (clear water) iron is soluble and dissolves in water. It is usually detected by taking a sample of water in a clear bottle or glass. Immediately after taking, the sample is clear. As the water sample stands, it gradually clouds and turns slightly yellow or brown as air oxidizes the iron. This usually occurs in 15 to 30 minutes. A water softener will remove moderate amounts of this type of iron (see specifications).

② Ferric (red water), and ③ Bacterial and organically bound irons are insoluble. This iron is visible immediately when drawn from a faucet because it has oxidized before reaching the home. It appears as small cloudy yellow, orange, or reddish suspended particles. After the water stands for a period of time, the particles settle to the bottom of the container. Generally these irons are removed from water by filtration. Chlorination is also recommended for bacterial iron.

continued

WATER AND WATER CONDITIONING, continued

④ Colloidal and inorganically bound iron is of ferric or ferrous form that will not filter or exchange out of water. In some instances, treatment may improve colloidal iron water, but always CONSULT A QUALIFIED WATER CHEMISTRY LAB before attempting to treat it. Colloidal iron water usually has a yellow appearance when drawn. After standing for several hours, the color persists and the iron does not settle, but remains suspended in the water.

Iron in water causes stains on clothing and plumbing fixtures. It negatively affects the taste of food, drinking water, and other beverages.

ACIDITY or acid water is caused by carbon dioxide, hydrogen sulfide, and sometimes industrial wastes.

It is corrosive to plumbing, plumbing fixtures, water heaters, and other water using appliances. It can also damage and cause premature failure of seals, diaphragms, etc., in water handling equipment.

A chemical analysis is needed to measure the degree of acidity in water. This is called the pH of water. Water testing below 6.9 pH is acidic. The lower the pH reading, the greater the acidity. A neutralizer filter or a chemical feed pump are usually recommended to treat acid water.

SEDIMENT is fine, foreign material particles suspended in water. This material is most often clay or silt. Extreme amounts of sediment may give the water a cloudy appearance. A sediment filter normally corrects this condition.

HOW THE WATER SOFTENER WORKS

SOFT WATER SERVICE, AND REGENERATION ...see illustrations, page 15

SERVICE

When the softener is providing soft water, it is called "Service". During service, hard water flows from the house main water pipe into the softener. Inside the softener resin tank is a bed made up of thousands of tiny, plastic resin beads. As hard water passes through the bed, each bead attracts and holds the hardness minerals. This is called ion-exchanging. It is much like a magnet attracting and holding metals. Water without the hardness minerals (soft water) flows from the softener and to the house pipes.

After a period of time, the resin beads become coated with hardness minerals and they have to be cleaned. This cleaning is called regeneration, or recharge. The Ultra demand timer automatically determines when regenerations occur. Regeneration is started at 2:00 a.m. (factory setting) by the softener timer, and consists of 5 stages or cycles. These are: FILL, BRINING, BRINE RINSE, BACKWASH, and FAST RINSE.

REGENERATION

● **FILL:** Salt, dissolved in water, is called brine. Brine is needed to clean the hardness minerals from the resin beads. To make the brine, water flows into the

AUTOMATIC HARD WATER BYPASS DURING REGENERATION

For emergency needs, **hard** water is available to the home during the regeneration cycles. However,

salt storage area during the fill stage as shown on page 15.

● **BRINING:** During brining, brine travels from the salt storage area, into the resin tank. Brine is the cleaning agent needed to remove the hardness minerals from the resin beads. The hardness minerals, and brine are discharged to the drain.

The nozzle and venturi create a suction to move the brine, maintaining a very slow rate to get the best resin cleaning with the least salt.

● **BRINE RINSE:** After a pre-measured amount of brine is used, the brine valve closes. Water continues to flow in the same path as during brining, except for the discontinued brine flow. Hardness minerals and brine flush from the resin tank, to the drain.

● **BACKWASH:** During backwash, water travels **up** through the resin tank at a fast flow rate, flushing accumulated iron, dirt, and sediments from the resin bed and to the drain.

● **FAST RINSE:** Backwash is followed by a fast flow of water **down** through the resin tank. The fast flow flushes brine from the bottom of the tank, and packs the resin bed.

After fast rinse, the softener returns to soft water service.

you should avoid using HOT water because the water heater will refill with the hard water.

★ NORTHSTAR AUTOMATIC WATER CONDITIONER

WATER FLOW THROUGH SOFTENER

SOFT WATER SERVICE

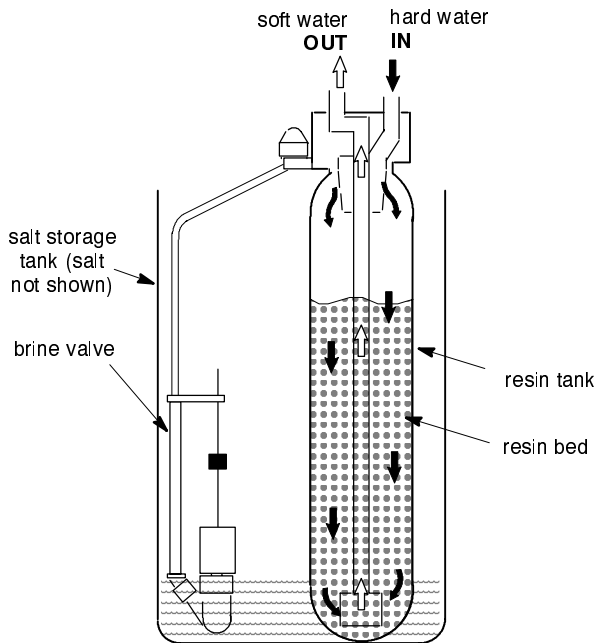

FILL

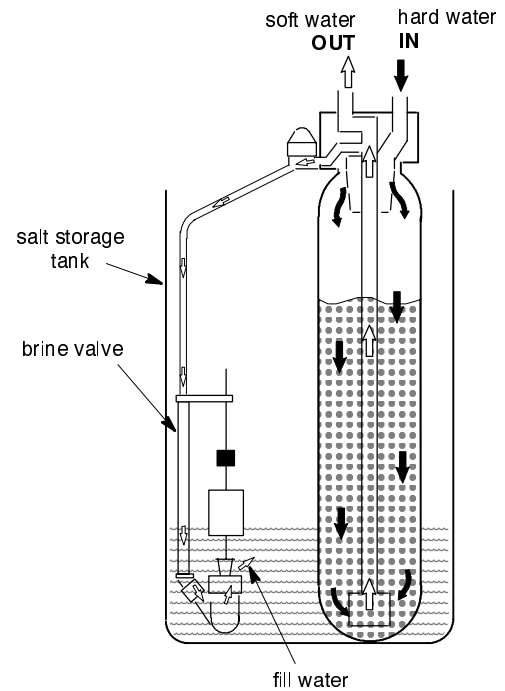

BRINING / BRINE RINSE

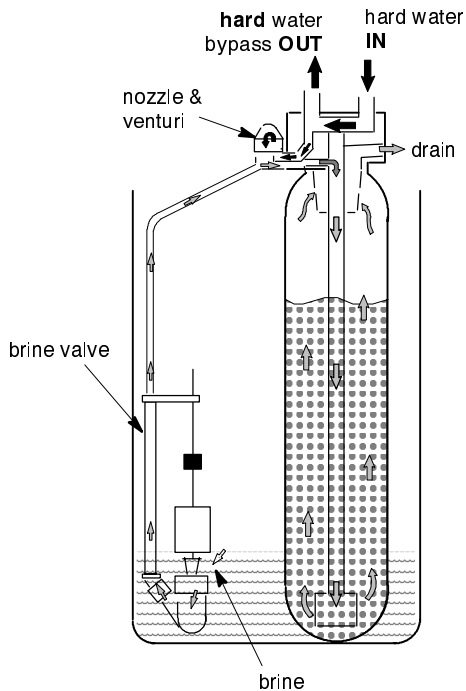

BACKWASH

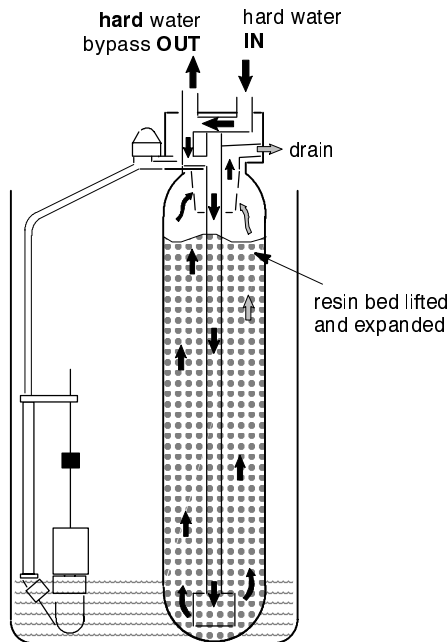

FAST RINSE

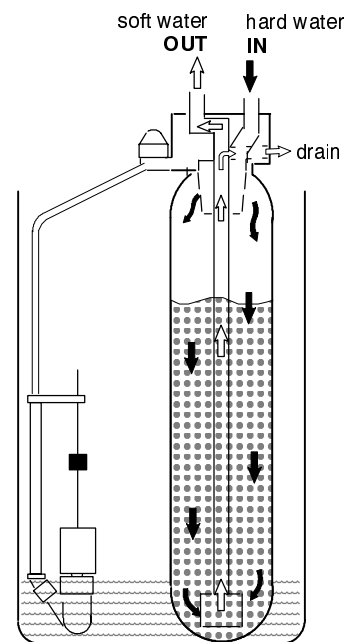

★NORTHSTAR AUTOMATIC WATER CONDITIONER

GENERAL WATER SOFTENER MAINTENANCE

CHECKING THE SALT STORAGE LEVEL, AND REFILLING (also see page 9 and 10)

Brine (salt dissolved in water) is needed for each and every regeneration. The water for making brine is metered into the salt storage area by the softener valve and timer. However, **you must keep the tank full of salt.** In humid areas, it is best to fill with less salt, more often.

WHEN TO REFILL WITH SALT: Check the salt level a few weeks after you install the softener and every week after that. Refill when the brine tank is from 1/3 to 1/2 full. Never allow the softener to use all the salt before you refill it. Without salt, you will soon have hard water.

Use clean water softener salt only, at least 99.5%

pure. NUGGET, PELLET or coarse SOLAR salts are recommended. **Do not use** rock, block, granulated, and ice cream making salts. They contain dirt and sediments, or mush and cake, and will create maintenance problems.

NOTE: Water softening **salt with iron removing additives:** Some salts have an additive to help the softener handle iron in the water supply. Although this additive may help to keep the softener resin clean, it may also release corrosive fumes that weaken and shorten the life of some softener parts.

BREAKING A SALT BRIDGE

Sometimes, a hard crust or salt bridge forms in the salt storage area. It is usually caused by high humidity or the wrong kind of salt. When the salt bridges, an empty space forms between the water and salt. Then salt will not dissolve in the water to make brine.

If the brine tank is full of salt, it is hard to tell if you have a salt bridge. Salt is loose on top, but the bridge is under it. The following is the best way to check for a salt bridge.

Salt should be loose all the way to the bottom of the tank. Take a broom handle, or like tool, and **carefully** push it down into the salt, working it up and down. If the tool strikes a hard object (be sure it's not the bottom or sides of the tank), it's most likely a salt bridge. Carefully break the bridge with the tool. **DO NOT** pound on the walls of the tank.

If the wrong kind of salt made the bridge, take it out. Then fill the tank with nugget or pellet salt only.

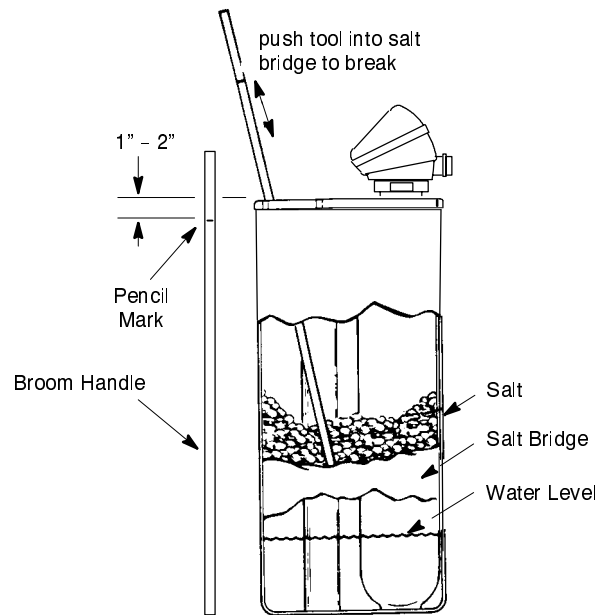

CLEANING IRON OUT OF THE WATER SOFTENER

Your water softener takes hardness minerals (calcium and magnesium) out of the water. Also, it can control some (see specifications, page 4) "clear water" iron. With clear water iron, water from a faucet is clear when first put into a glass. After 15 to 30 minutes, the water begins to cloud or turn rust colored. A water softener **WILL NOT** remove any iron that makes the water cloudy or rusty as it comes from the faucet (called red water iron). To take red water iron

out of water, or over the maximum of clear water iron, an iron filter or other equipment is needed. Your local dealer has trained people to help you with iron water problems.

If your water supply has clear water iron, periodic resin bed cleaning is needed. Clean the bed at least every six months, or more often if iron appears in the soft water between treatments. Follow directions on the resin bed cleaner container.

★NORTHSTAR AUTOMATIC WATER CONDITIONER

GENERAL WATER SOFTENER MAINTENANCE, continued

CLEANING THE NOZZLE AND VENTURI ASSEMBLY

A clean nozzle and venturi is needed for the softener to work right. This small unit makes the suction to move brine from the salt storage area to the resin tank during regeneration. If the nozzle and venturi becomes plugged with sand, silt, dirt, etc., the softener will not work and you will get hard water.

To get to the nozzle and venturi, remove the softener top cover. Be sure the softener is in service cycle (no water pressure at nozzle and venturi). Then, while holding the nozzle & venturi housing with one hand, turn off the cap. Lift out the screen support and screen, then the nozzle and venturi. Wash and rinse the parts in warm water until clean. If needed, use a small brush to remove iron or dirt. Also check and clean the gasket.

NOTE: Models in this manual have a small flow plug located in the nozzle and venturi, and a small cone shaped screen in the housing. Be sure to check and clean these parts.

Carefully replace all parts in the correct order. Lubricate the o-ring seal with silicone grease and place in position. Install and tighten the cap, **by hand only**. Do not over-tighten and break the cap or housing.

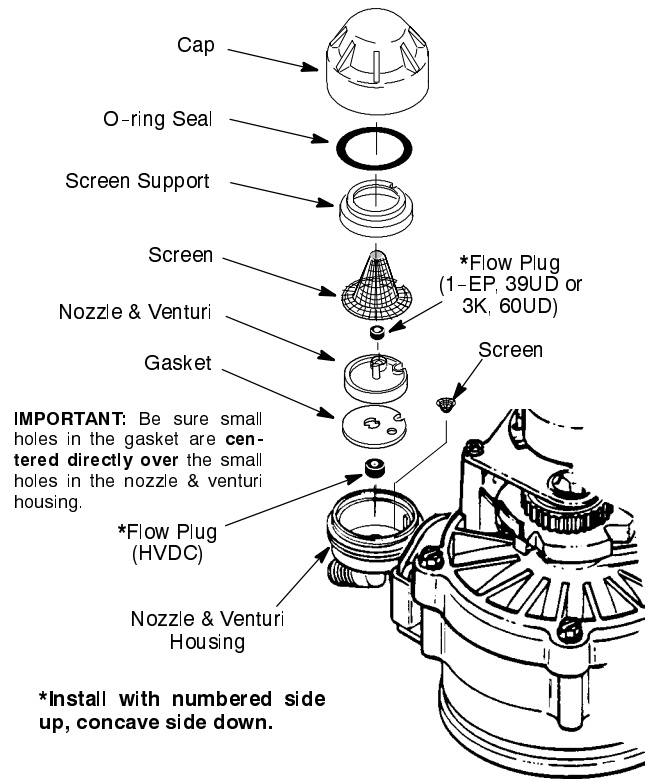

SERVICE CHECKLIST

NO SOFT WATER

No salt in storage tank: See page 16 to refill, then start a regeneration, or recharge.

Transformer unplugged at wall outlet, or disconnected from timer: Reconnect to electrical power and start a regeneration, or recharge.

Fuse blown, circuit breaker popped, or circuit mistakenly switched off: Check and resolve as needed. Then, start a regeneration, or recharge.

Plumbing bypass valve(s) in "bypass" position: Refer to page 6 or 8 and position valve(s) for "service" to direct soft water to house pipes. Then, start a regeneration, or recharge.

Timer not programmed: See pages 10 and 11.

Nozzle & venturi dirty, or salt in storage tank bridged: See page 16 and above to clean. Then, start a regeneration, or recharge.

WATER INTERMITTENTLY HARD

Possible increase in water hardness: See page 11.

Hot water used when softener is regenerating: The water heater will refill with hard water... see Automatic Hard Water Bypass During Regenerations, page 14.

Leaking faucet or toilet valve: A small leak will waste hundreds of gallons of water in just a few days. Fix all water leaks immediately.

★NORTHSTAR AUTOMATIC WATER CONDITIONER

Ultra II DEMAND TIMER FEATURES, SETTINGS, AND SERVICE

NOTE: SEE PAGES 10 and 11 TO SET THE TIMER TO THE CORRECT TIME OF DAY, AND WATER HARDNESS NUMBER.

NORMAL OPERATION, TIMER DISPLAY

During normal operation, the present time of day, and AM or PM, show in the time display area. When the demand computer determines a regeneration is needed, RECHARGE TONIGHT begins to flash in the display, along with the present time. RECHARGE TONIGHT flashes until the next



regeneration start time, then changes to RECHARGE NOW, which flashes until the regeneration is over. The display also shows the current cycle in the regeneration process. When the valve is in transition between cycles, both indicators flash.

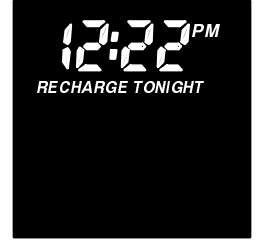

feature: OTHER DATA DISPLAYS

With repeated presses of the DATA button, you can scan through four displays of operational information. This data appears in the bottom portion of the display area. These are:

- DATA
- REMAINING CAPACITY
- FLOW RATE, GPM
- GALLONS TODAY
- AVG. DAILY GALLONS

CAPACITY (remaining) - This is the percentage of water softening capacity remaining. Immediately after a regeneration, 100% shows. Then, as water is used, the percentage decreases until the next regeneration. During regenerations, the percentage increments upward.

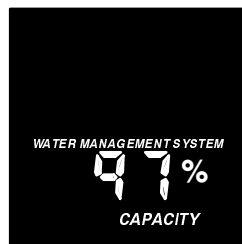

FLOW RATE, GPM* - When using soft water, this display shows the gallon per minute flow rate passing through the softener. Zero shows if water is not in use.

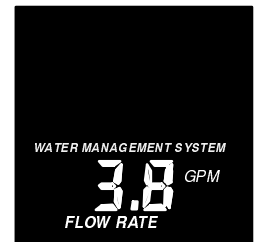

GALLONS* TODAY - Each day, beginning at midnight, the timer keeps a running count of the total gallons of water passing through the softener.

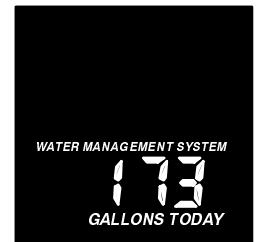

NOTE: Zero (0%) shows until after the first regeneration begins, after connecting to electrical power.

AVERAGE DAILY GALLONS* - The figure displayed is the average gallons of water used by the household each day, over the past seven day period.

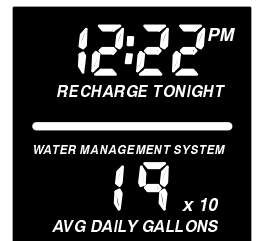

* If preferred, you can set the timer to show the reading in liters instead of gallons... see page 20. If gallons today, or average daily gallons exceeds 1999, a (x 10) indicator appears. This means you must multiply the number shown times 10.

feature: OPTIONAL RECHARGE CONTROLS

Sometimes, a manually started regeneration (recharge) may be desired, or needed. Two examples are:

... You have used more water than usual (house guests, extra washing, etc.) and you may run out of soft water before the next regeneration.

... You did not refill the storage tank with salt before it was all gone.

Use one of the following features to start a regeneration immediately, or at the next preset regeneration start time.

continued

★ NORTHSTAR AUTOMATIC WATER CONDITIONER

Ultra II DEMAND TIMER FEATURES, SETTINGS, AND SERVICE, continued

RECHARGE NOW



Press and *hold* in the TOUCH - HOLD button *until* **RECHARGE NOW** starts to flash in the time display area. The softener begins an immediate regeneration, and when over in about two hours, you will have a new supply of soft water. Once started, you cannot cancel this regeneration.

RECHARGE TONIGHT



Touch (*do not hold*) the TOUCH - HOLD button, and **RECHARGE TONIGHT** flashes in the time display area. A regeneration will occur at the next preset regeneration start time. If you decide to cancel this regeneration, *before it has started*, touch the same button once more.

feature: **PROGRAM MEMORY**

If electrical power to the softener is interrupted, the time display is blank, but the timer keeps correct time for about 24 hours. When power is restored, you have to reset the present time **only if** the display is flashing. **All** other settings are maintained and never require resetting unless a change is desired.

If the time *is* flashing after a long power outage, the softener continues to work as it should to provide you with soft water. However, regenerations may occur at the wrong time of day until you reset the timer to the correct time of day, page 11.

setting: **REGENERATION (STARTING) TIME, MAXIMUM DAYS BETWEEN REGENERATIONS, EFFICIENCY MODE, 97% FEATURE AND HEAVY DUTY BACKWASH**

NOTE: Each of these settings has a factory set default value. The defaults are: Regeneration start time - 2:00AM; Maximum days between regenerations - 0 (*display shows dY -*); Efficiency Mode - ON; 97% Feature - OFF; Heavy duty backwash - OFF. The defaults suit most installations. However, depending on water supply quality, household peak water use hours, etc., adjustment is available to meet specific needs. To make a change, read and do the following.

continued

★NORTHSTAR AUTOMATIC WATER CONDITIONER

Ultra II DEMAND TIMER FEATURES, SETTINGS, AND SERVICE, continued

REGENERATION (START) TIME: At the 2:00AM regeneration start time, the softener begins regenerations at that time, ending no later than 4:00AM. This is a good time in most households because water is not in use (see Automatic Bypass on page 14). If a different time would be better for your needs, do steps 1, 2, 4, 6, 8 and 10 to change the starting hour.

MAXIMUM DAYS BETWEEN REGENERATIONS: The default setting allows the timer to control regeneration frequency based on water usage readings from the water meter. It provides the most economical operation. You can set a maximum time (in days) between regenerations. For example, no more than 3 days will pass without a regeneration occurring if you set dY 3 in the display. A 1 to 7 day setting is available. To make a change from the default setting, do steps 1, 2, 3, 4, 6, 8 and 10.

EFFICIENCY MODE: When this feature is ON, the unit will operate at salt efficiencies of 4000 grains of hardness per pound of salt or higher. (May recharge more often using smaller salt dosage and less water). When this is ON the efficiency icon  will show in the lower right hand corner of the display. To make a change from the default setting, do steps 1, 2, 4, 5, 6, 8 and 10.

HEAVY DUTY BACKWASH: When set to ON, the backwash cycle of regeneration will be 10 minutes long instead of the normal 7 minute length. This is beneficial on some water supplies high in iron or sediment content. To conserve water, on clean supplies, be sure OFF shows. To change this setting, do steps 1, 2, 4, 6, 7, 8 and 10.

SET 97% FEATURE: By setting to On, unit will automatically recharge when 97% capacity has been used, at any time of day. To change this setting, do steps 1, 2, 4, 6, 8, 9 and 10.

1. Beginning from the present time display, press and *hold* in the SET button until 2:00 AM begins to flash, RECHARGE TIME remains steady.



2. Press the up or down arrow to display the desired start time. The up arrow moves the time ahead; the down arrow moves the time backward. Press the SET button to select time and move to next setting.

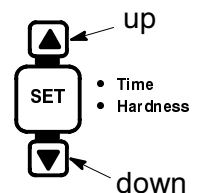

3. dY - flashes, with RECHARGE remaining steady. Pressing the up arrow will increase the number of days, the down arrow will decrease the number of days.

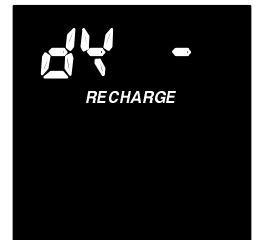

4. Press the SET button to select and move to next setting.

5. On flashes and the efficiency icon  shows in the lower right hand corner of the screen. Use the up or down arrows to toggle the efficiency mode either ON or OFF.



6. Press the SET button to select and move to next setting.

7. HEAVY BACKWASH and flashing OFF shows in the display. Use the up or down arrows to toggle the heavy backwash either ON or OFF.



8. Press the SET button to select and move to next setting.

9. Display toggles between 97 Recharge and OFF. Use the up or down arrows to toggle this setting either ON or OFF.

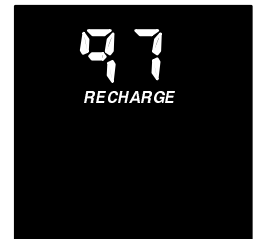

10. Press the SET button to select and return to the present time display.

★NORTHSTAR AUTOMATIC WATER CONDITIONER

Ultra II DEMAND TIMER FEATURES, SETTINGS, AND SERVICE, continued

setting: **MODEL CODE, 12 OR 24 HOUR CLOCK, AND GALLONS OR LITERS MEASURE . . .**

NOTE: The model code is factory set at assembly and testing. The hour clock and water measure have factory set default values. The defaults are: 12 or 24 hour clock – 12; Gallons or liters measure – *gallons*. The model code should never require resetting, but to check, or to set if previously omitted, read below. The defaults suit most installations. However, to make a change, read and do the following.

MODEL CODE: The *timer must have the right model code set* to operate the softener correctly. The correct code settings are:

▶ For model NSCA39UD it must show **A-31**.

▶ For model NSTA60UD it must show **A-63**.

If **A- - -** is flashing in the display, do steps 2, 3, 5 and 7.

To check for the correct code setting, and to reset if needed, do steps 1, 2, 3, 5 and 7.

12 OR 24 HOUR CLOCK: With 12 hr set, all time displays are in standard clock time... 12:00AM to 11:59PM. If 24 hr is set, time displays are in military time... 0100 (1:00AM) to 0000 (midnight). To change from the 12 hr setting, do steps 1, 3, 4, 5, and 7.

GALLONS OR LITERS MEASURE: All water flow rate and usage displays are in gallons with the default GALS setting. If reset to litErs, the same displays are shown in liters. Use steps 1, 3, 5, 6 and 7 to change.

1. Beginning from the present time display, press and *hold* in the SET button *until* 2:00 AM (or as otherwise set), and RECHARGE TIME begins to flash.



2. Press and *hold* in the SET button again. Either A- - - or a previously set code will appear. If setting is needed, use the up or down arrow to **set A-31** or **A-63**, as needed.

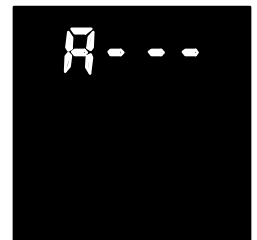

3. Press SET to to select and move to next screen.

4. 12 hr flashes along with TIME. To change the display to 24 hr, use the up arrow. Use the down arrow to reset to 12 hr.



5. Press SET to select and move to next screen.

6. GALS flashes, along with GALLONS. Use the up arrow to change to the liter setting. Use the down arrow to return to the gallon setting.

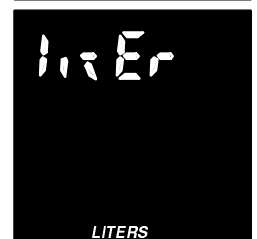
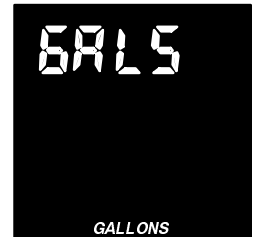

7. Press the SET button a final time to return to the present time display.

★NORTHSTAR AUTOMATIC WATER CONDITIONER

Ultra II DEMAND TIMER FEATURES, SETTINGS, AND SERVICE, continued

feature / service: **AUTOMATIC ELECTRONIC DIAGNOSTICS**

The timer computer has a self-diagnostic function for the electrical system (except input power and water meter). The computer monitors the electronic components and circuits for correct operation. If a malfunction occurs, an error code appears in the timer display.

The following chart shows the error codes that could appear, and *possible* defects for each code. While an error code is displayed, the TOUCH/HOLD and DATA buttons remain operable so you can perform the Manual Initiated Electronics Diagnostic.

	ERROR CODE DISPLAYED			
	Err 01	Err 03	Err 04	Err 05
POSSIBLE DEFECT	▶ motor inoperative ▶ switch	▶ wiring harness, or connection to switch ▶ valve defect causing high torque	▶ position	▶ timer (PWA)
TO REMOVE AN ERROR CODE: (1) unplug transformer (2) correct defect (3) plug transformer in (4) Wait for at least 6 minutes. The error code will return if the reason for the error code was not corrected.				

feature / service: **ELECTRONIC SYSTEM PROFILE**

The Ultra demand timer ESP feature provides the homeowner or servicer with the latest in softener performance and electronic diagnostic technology. ESP is the transmission of electronic data from the softener timer, through a telephone, to a remote personal computer equipped to receive the data. The personal computer decodes the data and provides a detailed report of the softener's up to date performance. Some of the information ESP provides includes:

- ☞ average daily gallons of **soft** water used by the household
- ☞ average time between recharges
- ☞ days since the last recharge
- ☞ total number of recharges since start-up
- ☞ if an electrical power outage occurred, and how long it lasted
- ☞ current status of the following electrical components, and if a problem was found in a circuit
 - ★ computer board
 - ★ valve motor
 - ★ softener water meter
 - ★ wire harness
 - ★ switch (valve positioning)

This report is immediately available to trained technicians. With this, they are able to determine if an electrical problem exists, based on factual, current information, and to offer expert advice if needed. A printout of this report is also available for a nominal charge. Ask about it when you call the toll free number shown on the next page.

★NORTHSTAR AUTOMATIC WATER CONDITIONER

Ultra II DEMAND TIMER FEATURES, SETTINGS, AND SERVICE, continued

HOW TO SEND AN ESP TRANSMISSION

NOTE: **Please read** the following steps carefully **before you call** the toll free number. It is important to use the procedures correctly, to transmit a good, decodable message.

1. Press the ESP button, on the timer faceplate, to display the toll free number to call:

CALL

1 - 800 - 754 - 7027

Note: It will take a few seconds for all the screens to display.

1800

2. To identify your ESP transmission, give the representative your name and complete address. Inform the representative if you would like to speak with a technician, and if you need a copy of the report, or both. The representative will connect you with a transmission line.

754

7027

NOTE: To provide you with faster service, call the toll free number immediately after installation of your Ultra softener, and register the above information.

3. Hold the telephone mouthpiece about 1" from the ESP speaker on the timer faceplate.

4. Holding the telephone steady, press the ESP button once again. A "beeping" sound begins immediately. The transmission is complete when the beeping stops, in about 20 seconds.

SEnd

NOTE: **Loud background noise may interfere with the ESP transmission.**

5. Stay on the line for further assistance.

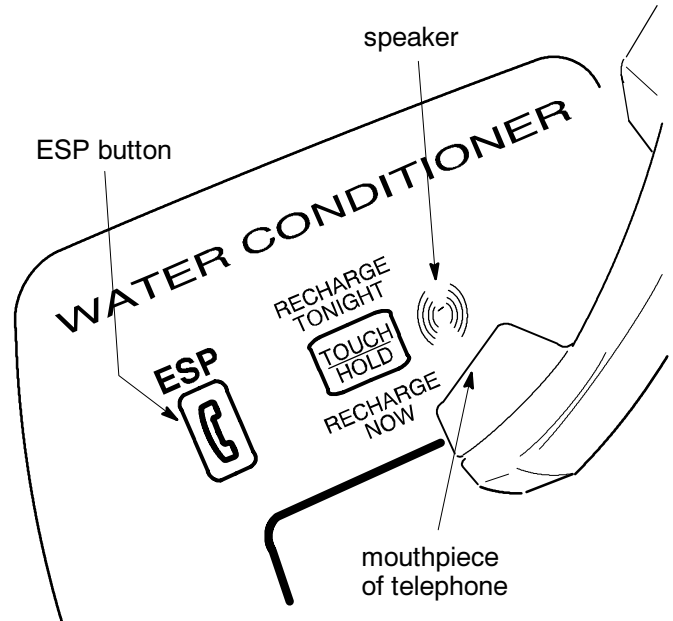

★NORTHSTAR AUTOMATIC WATER CONDITIONER

Ultra II DEMAND TIMER FEATURES, SETTINGS, AND SERVICE, continued

service: *TIMER / SOFTENER, SERVICE CHECKOUT PROCEDURE*

If you are not getting soft water, and an error code is not displayed, use the procedures below to find the problem. First, make the following visual checks.

VISUAL CHECKS: (1) Is there electrical power to the outlet the softener transformer is plugged into?

(2) Is there salt in the storage tank? (3) Is the plumbing bypass valve(s) directing water for soft water service... see pages 6 and 8? (4) Is the valve drain hose open to the drain, not elevated too high, and unobstructed? If you do not find a problem with the visual checks, continue below.

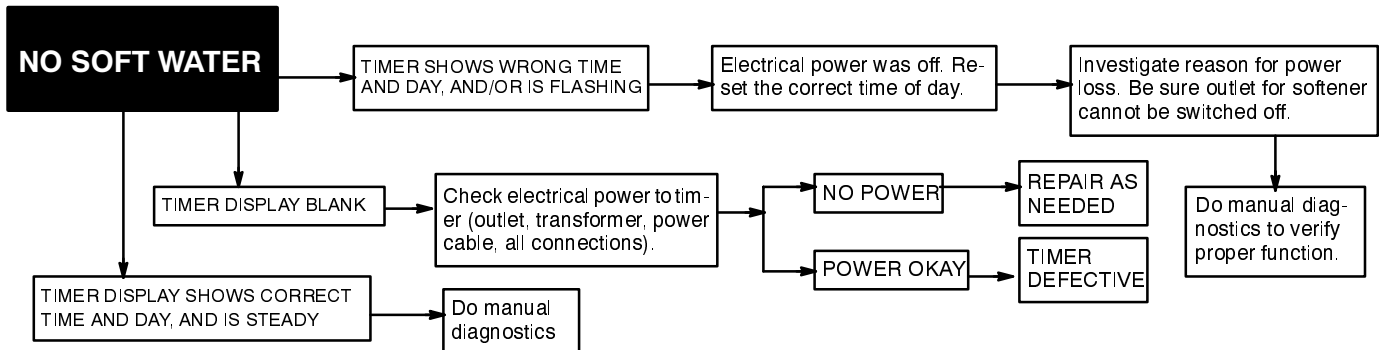

service: *MANUAL INITIATED ELECTRONICS DIAGNOSTIC*

1. To enter diagnostics, press and hold the DATA button until the display appears as shown here. The dY and number, in the top part of the display, is days since the last recharge. See (A) and (B) following, explaining the bottom portion of the display.

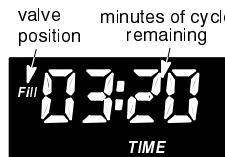
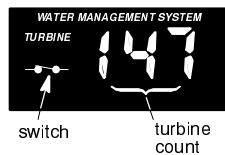

NOTE: If the softener is in the middle of a regeneration, the top part of the display shows the cycle of regeneration, and minutes of the cycle remaining. If two cycle names are flashing, the valve is in transition between the cycles.

(A) The 3 digits, under WATER MANAGEMENT SYSTEM, indicate water meter operation as follows:

◆ **000** (steady) = soft water not in use...no flow through the meter.

— OPEN A NEARBY SOFT WATER FAUCET —

◆ **000 to 140** (continual) = repeats display for each gallon of water passing through the meter.

If you don't get a reading in the display, with faucet open, pull the sensor from the valve outlet port. Pass a small magnet back and forth in front of the sensor. You should get a reading in the display. If you get a reading, unhook the in and out plumbing and check the turbine for binding.

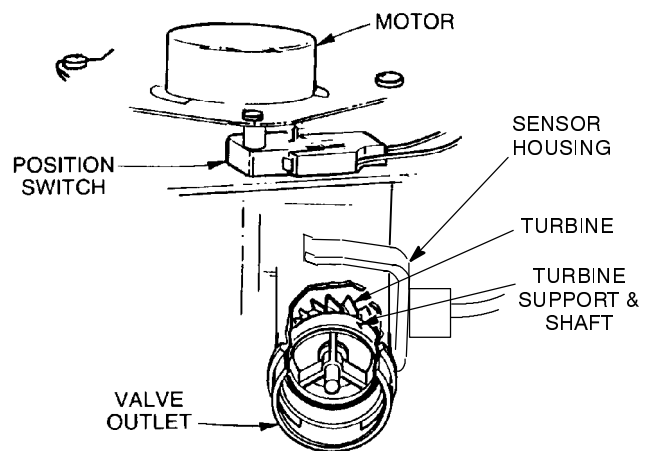

★NORTHSTAR AUTOMATIC WATER CONDITIONER

Ultra II DEMAND TIMER FEATURES, SETTINGS, AND SERVICE, continued

(B) This display segment (→↗↘←), in the following table, indicates an open POSITION switch. The other indicates a closed switch. Use the TOUCH - HOLD button to manually advance the valve into each cycle and check correct switch operation.

CORRECT SWITCH DISPLAYS	VALVE CYCLE STATUS
	Valve in service, fill, brining, backwash or fast rinse position.
	Valve rotating from one position to another.

service: MANUAL ADVANCE REGENERATION CHECK

This check verifies proper operation of the valve motor, brine tank fill, brine draw, regeneration flow rates, and other timer - valve functions. **First, make the initial checks, and the manual initiated diagnostics.**

NOTE: The face plate display must show a steady time (not flashing).

1. Press the TOUCH - HOLD button and *hold* in for 3 seconds. RECHARGE NOW begins to flash as the softener enters the fill cycle of regeneration. Remove the brinewell cover and, using a flashlight, observe fill water entering the brine tank.

▶ If water **does not** enter the tank, look for an obstructed nozzle, venturi, fill flow plug, brine tubing, or brine valve riser pipe.

2. After observing fill, press the TOUCH - HOLD button to move the softener into brining. A slow flow of water to the drain will begin. Verify brine draw from the brine tank by shining a flashlight into the brinewell and observing a noticeable drop in the liquid level.

NOTE: Be sure a salt bridge is not preventing water with salt contact.

▶ If the softener does not draw brine...
 ...nozzle and/or venturi dirty or defective.
 ...nozzle and venturi not seated properly on gasket.
 ...restricted drain (check drain fitting and hose).
 ...defective nozzle and venturi seal.
 ...other inner valve defect (rotor seal, rotor & disc, wave washer, etc.).

2. Press the DATA button again. This diagnostic display, shows the total number of *recharges* (top) since the timer was connected to electrical power.

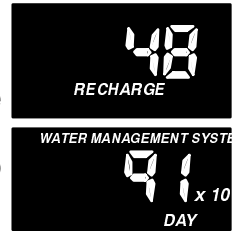

The number of *days* since the timer was connected to electrical power, is shown in the bottom part of the display. If over 1999 days, a (x 10) indicator shows, meaning you must multiply the number shown times 10.

3. Press DATA once again to return the present time to the display.

3. Press TOUCH - HOLD to move the softener into fast rinse. Again look for a fast drain flow. Allow the softener to rinse for a few minutes to flush out any brine that may remain in the resin tank from the brining cycle test.

4. To return the softener to service, press TOUCH - HOLD.

WIRING SCHEMATIC

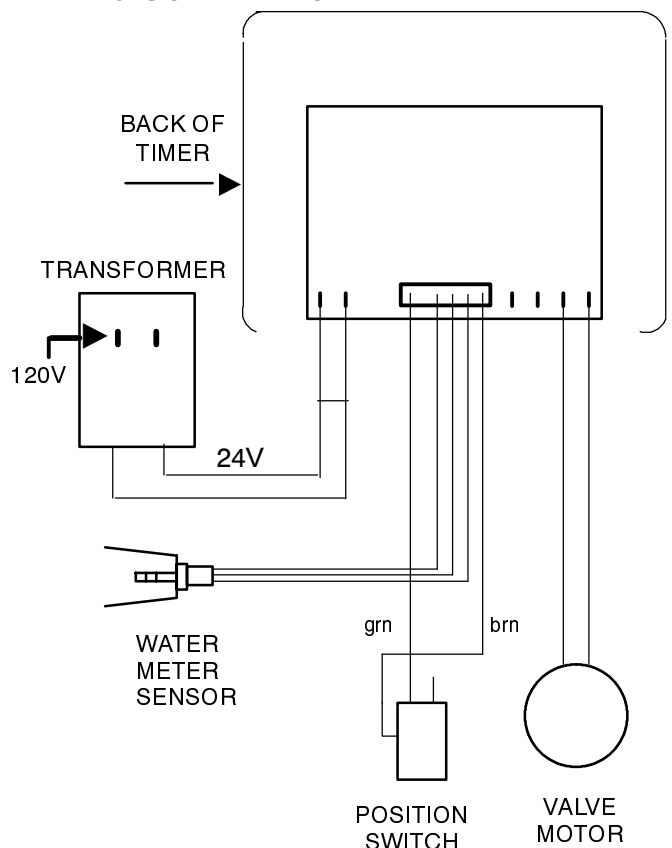

★ NORTHSTAR AUTOMATIC WATER CONDITIONER

WATER FLOW THROUGH VALVE

SERVICE CYCLE

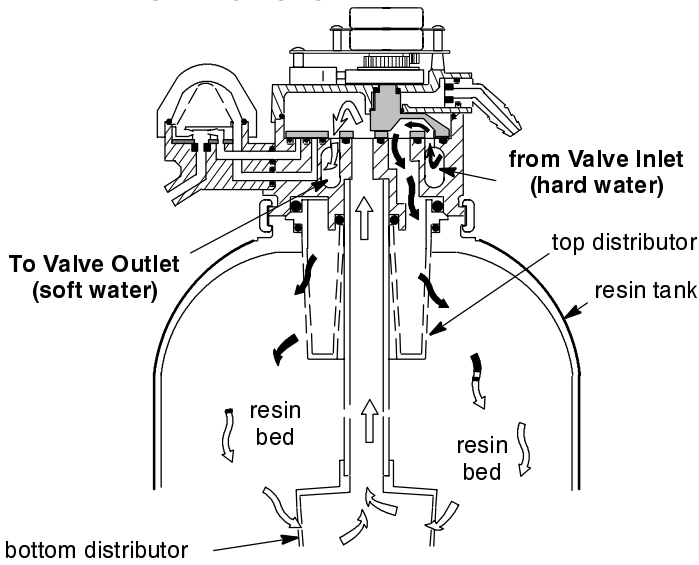

FILL CYCLE

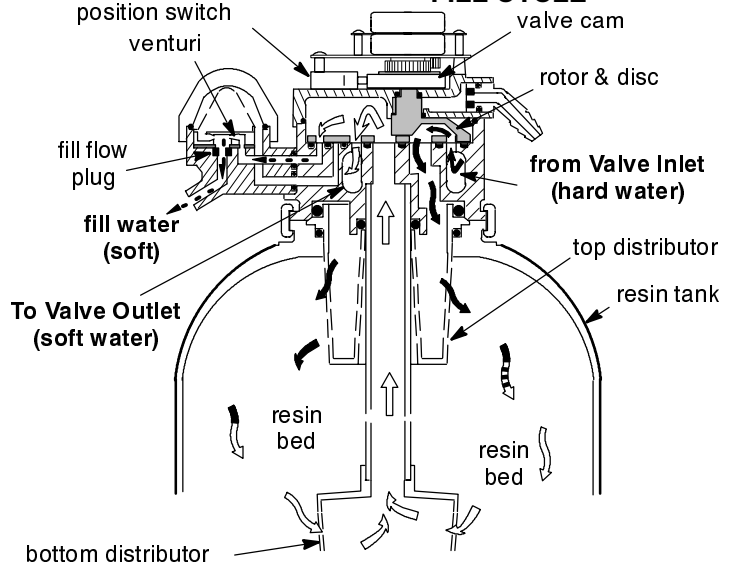

BRINING and BRINE RINSE CYCLES

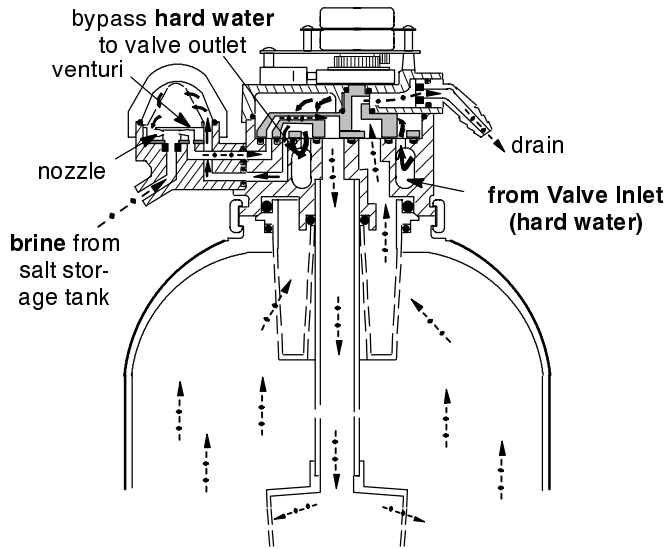

BACKWASH CYCLE

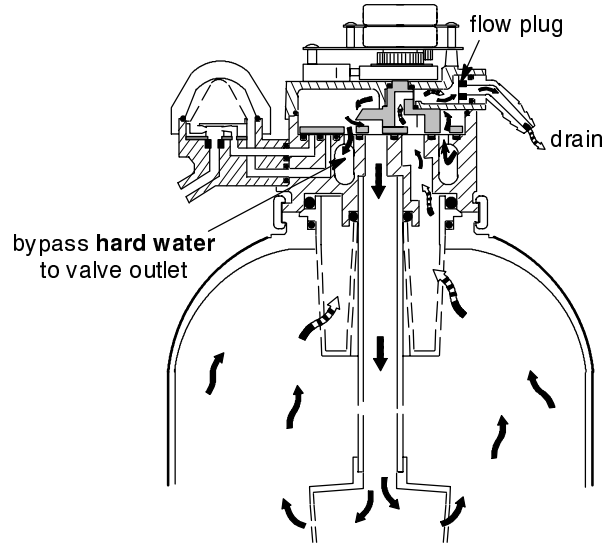

FAST RINSE CYCLE

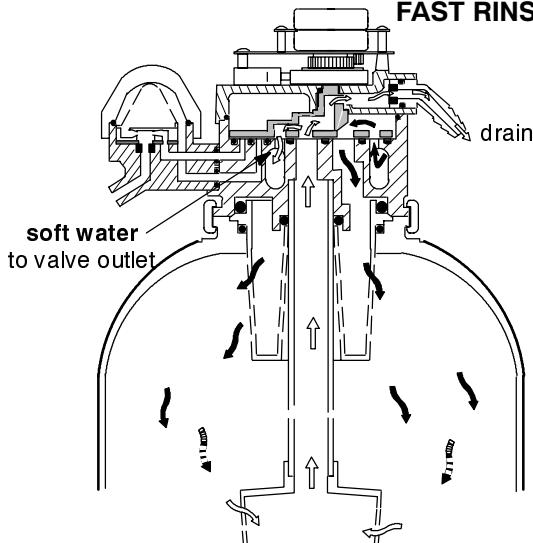

CYCLE TIMES - MINUTES

	MODEL 39	MODEL 60
*FILL	2 - 11	8 - 22
*BRINING & BRINE RINSE	96 - 106	55 - 91
BACKWASH	7	12
FAST RINSE	3	5

*Time varies with the operating level (grains capacity restored) each regeneration.

★NORTHSTAR AUTOMATIC WATER CONDITIONER

★ NORTHSTAR AUTOMATIC WATER CONDITIONER

REPAIR PARTS

SOFTENER ASSEMBLY

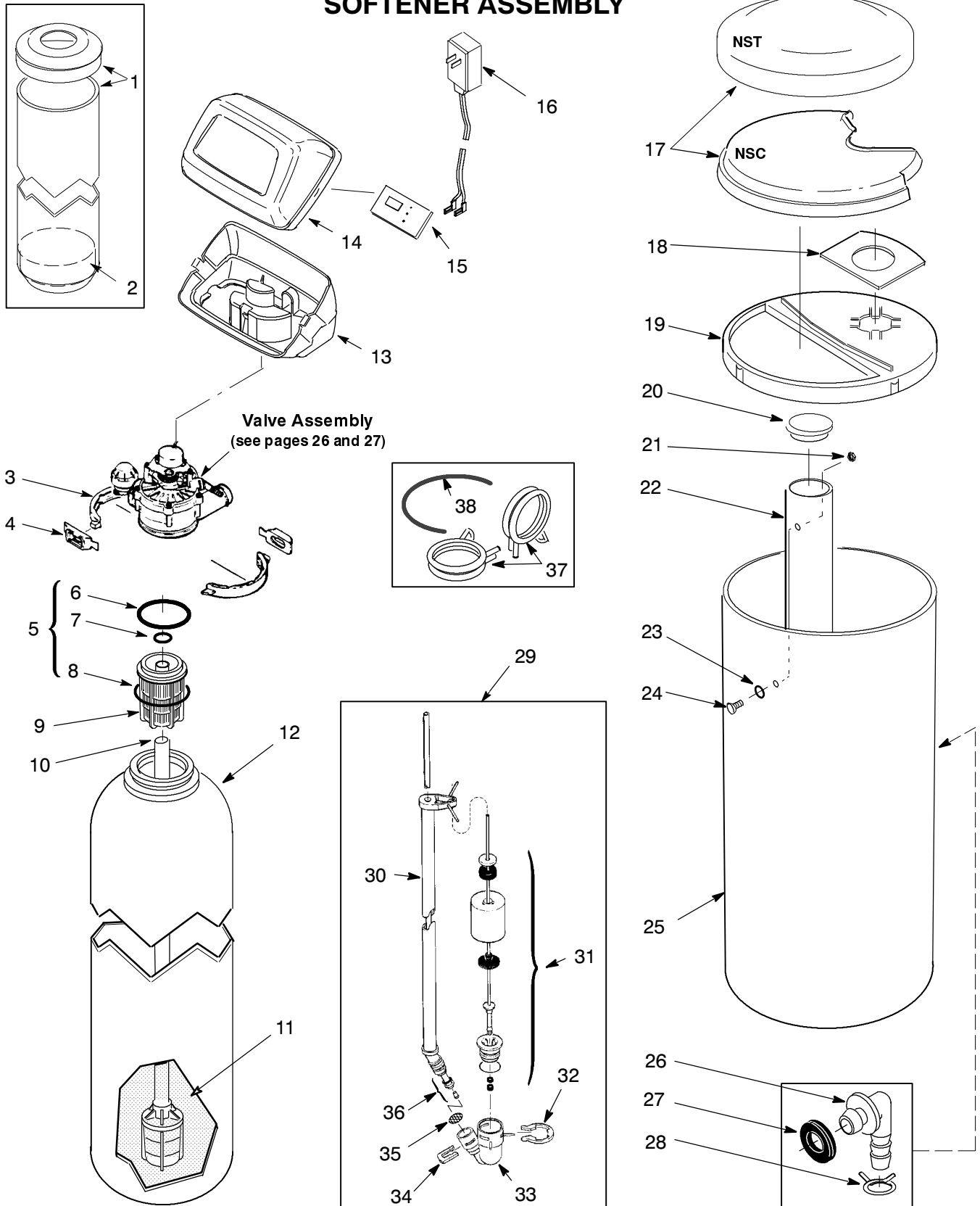

★NORTHSTAR AUTOMATIC WATER CONDITIONER

REPAIR PARTS

KEY NO.	PART NO.	DESCRIPTION OF PART	KEY NO.	PART NO.	DESCRIPTION OF PART
1	7246649	Shroud, Model NSTA60UD (Includes Key No. 2)	18	7163689	Vapor Barrier
2	7141205	Base	19	7178626	Rim
3	7176292	Clamp Section (2)	20	7155115	Brinewell Cover
4	7088033	Clamp Retainer (2)	21	7082150	Wing Nut, 1/4 - 20
5	7112963	O-ring Seal Kit	22	7100819	Brinewell
6	--	O-ring Seal, 2-7/8 in. x 3-1/4 in.	23	7003847	O-ring
7	--	O-ring Seal, 13/16 in. x 1-1/16 in.	24	7248875	Screw, 1/4 - 20 Nylon
8	--	O-ring Seal, 2-3/4 in. x 3 in.	25	7161831	Repl. Brine Tank
9	7077870	Top Distributor	26	1103200	Hose Adaptor
10	7105047	Repl. Bottom Distributor	27	9003500	Grommet
11	0501741	Resin, 26-1/2 lbs (1/2 cu ft)	28	0900431	Hose Clamp
-	0502272	Resin, 53 lbs (1 cu ft)	29	7116488	Brine Valve Assembly
12	▼	Resin Tank	30	7095470	Brine Tube
-	7161849	9" dia x 40", Models NSCA39UD	31	7113008	Float, Stem & Guide Assembly
-	7113074	12" dia x 54", Model NSTA60UD	32	1205500	Clip
13	7189449	Bottom Cover	33	7092252	Brine Valve Body
14	7174868	Faceplate Cover (also order following decal)	34	7080653	Clip
-	7190026	Decal, Faceplate	35	7131365	Screen
15	7246372	Timer (PWA)	36	7113016	Tubing Assembly
16	7252373	Transformer	37	7163427	Ground Clamp (2)
17	▼	Salt Cover	38	7207726	Ground Wire
-	7192785	Model NSCA39UD			
-	7180437	Model NSTA60UD			

★ NORTHSTAR AUTOMATIC WATER CONDITIONER

REPAIR PARTS

VALVE ASSEMBLY

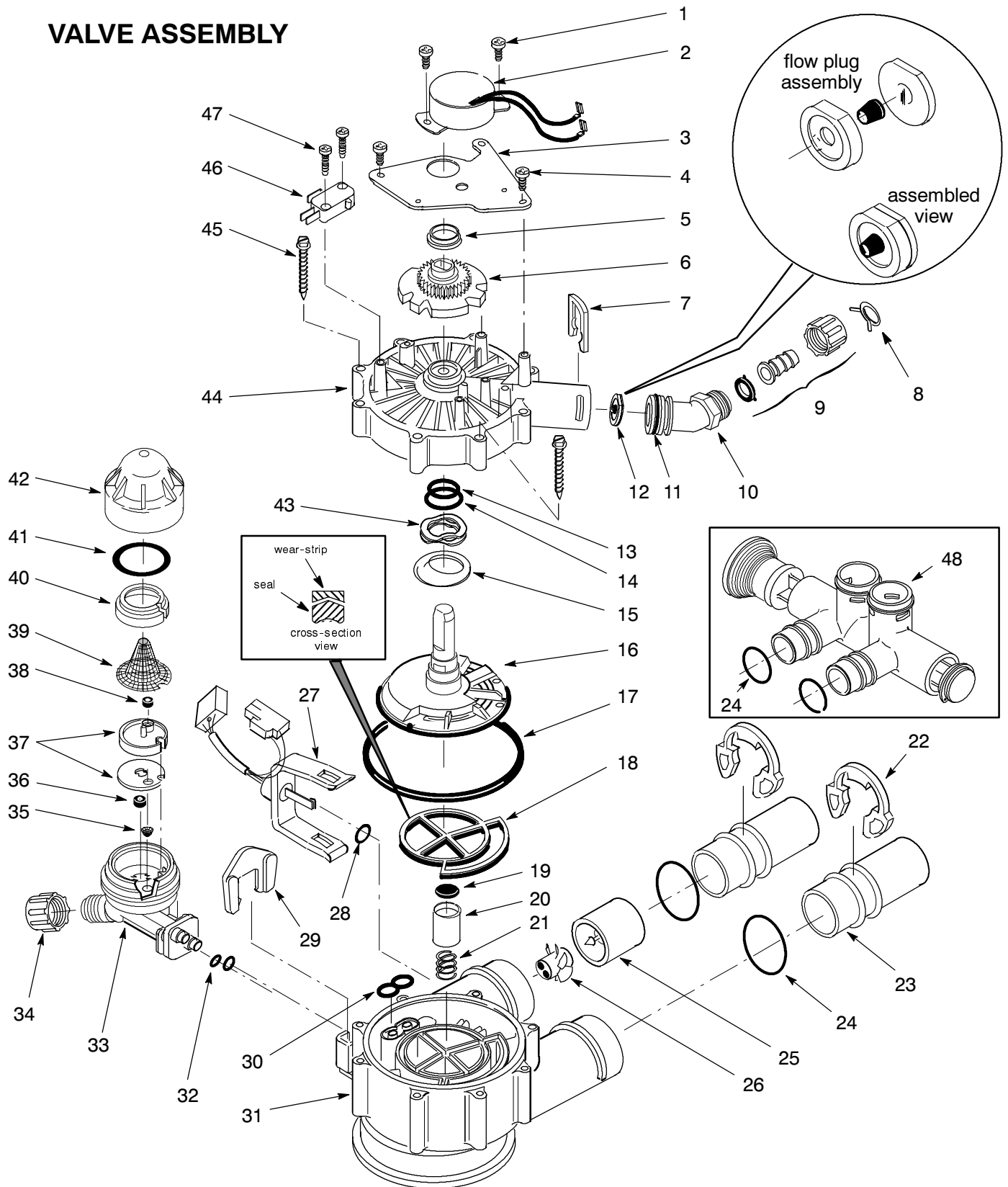

★ NORTHSTAR AUTOMATIC WATER CONDITIONER

REPAIR PARTS

KEY NO.	PART NUMBER	DESCRIPTION OF PART	KEY NO.	PART NUMBER	DESCRIPTION OF PART
1	7131755	Screw, #6-20 x 7/8 (2 req.)	31	7171145	Valve Body
2	7133008	Motor (incl. 2 ea. of Key No. 1)	32	7170319	O-ring, 1/4 x 3/8 (2 req.)
3	7218816	Motor Plate	33	➡	Nozzle & Venturi Asm. (incl. Key Nos. 33, and 35 through 42)
4	0900857	Screw, #6-20 x 3/8 (3 req.)	-	7187065	Model NSCA39UD
5	7171250	Bearing	-	7197777	Model NSTA60UD
6	7219545	Cam and Gear	34	1202600	Nut — Ferrule
7	7169180	Clip (Drain)	35	7095030	Cone Screen
8	0900431	Hose Clamp	36	1148800	Flow Plug, .3 gpm
9	7250347	Drain Line Adaptor	37	➡	Nozzle and Venturi — Gasket Kit
-	7139999	Drain Tubing (not shown)	-	7187772	Model NSCA39UD
10	7172793	Drain Hose Adaptor	-	7198642	Model NSTA60UD
11	7170288	O-ring, 15/16 x 1-3/16	-	7204362	Gasket (only) NSCA39UD
12	➡	Flow Plug	-	7190547	Gasket (only) NSTA60UD
-	7178171	Model NSCA39UD (2.0)	38	➡	Flow Plug
-	7197808	Model NSTA60UD, (3.0)	-	0521829	Model NSCA39UD, (.1)
13	-	O-ring, 5/8 x 13/16 ◆	-	7147798	Model NSTA60UD, (.22)
14	-	O-ring, 1-1/8 x 1-1/2 ◆	39	7146043	Screen
15	7174313	Bearing, Wave Washer	40	7167659	Screen Support
16	7185500	Rotor & Disc	41	7170262	O-ring, 1-1/8 x 1-3/8
17	-	O-ring, 4-1/2 x 4-7/8 ◆	42	7199729	Cap
18	-	Rotor Seal ◆	43	7175199	Wave Washer
19	-	Seal ◆	44	7171161	Valve Cover
20	7171187	Plug (Drain Seal)	45	7172997	Screw, #10 x 2-5/8 (8 req.)
21	7129889	Spring	46	7145186	Switch
22	7089306	Clip (2 req.)	47	7140738	Screw, #4-24 x 3/4 (2 req.)
23	7077642	Copper Tube, 1" (2 req.)	48	7214383	Bypass Valve (Includes following parts)
24	7170262	O-ring, 1-1/8 x 1-3/8 (4 req.)	-	7172882	Stem
25	7094898	Turbine Support	-	7173016	O-ring, 1.109 I.D. x 1.387 O.D. (4)
26	7101548	Turbine	-	7175238	C-ring
27	7248722	Sensor Housing/Wiring Asm	◆	7185487	Seal Kit (incl. Key Nos. 13, 14, 17, 18, 19 and 30)
28	0900060	O-ring			
29	7081201	Retainer (Nozzle & Venturi)			
30	-	Seal (Nozzle & Venturi) ◆			

★NORTHSTAR AUTOMATIC WATER CONDITIONER

PARTS RETURN TAGS

If you have a defective part or assembly under warranty, please fill in a parts return tag. Cut out the tag, complete all information requested, and include it with the defective part when you return it to the place where you purchased the conditioner.

PARTS RETURN TAG			PARTS RETURN TAG		
_____ CUSTOMER'S NAME			_____ CUSTOMER'S NAME		
_____ STREET ADDRESS			_____ STREET ADDRESS		
_____ CITY	_____ STATE	_____ ZIP CODE	_____ CITY	_____ STATE	_____ ZIP CODE
_____ CONDITIONER MODEL NUMBER		_____ SERIAL NUMBER	_____ CONDITIONER MODEL NUMBER		_____ SERIAL NUMBER
_____ DATE PURCHASED		_____ DATE PART FAILED	_____ DATE PURCHASED		_____ DATE PART FAILED
NORTH STAR 1890 WOODLANE DRIVE WOODBURY, MN 55125			NORTH STAR 1890 WOODLANE DRIVE WOODBURY, MN 55125		
PARTS RETURN TAG			PARTS RETURN TAG		
_____ CUSTOMER'S NAME			_____ CUSTOMER'S NAME		
_____ STREET ADDRESS			_____ STREET ADDRESS		
_____ CITY	_____ STATE	_____ ZIP CODE	_____ CITY	_____ STATE	_____ ZIP CODE
_____ CONDITIONER MODEL NUMBER		_____ SERIAL NUMBER	_____ CONDITIONER MODEL NUMBER		_____ SERIAL NUMBER
_____ DATE PURCHASED		_____ DATE PART FAILED	_____ DATE PURCHASED		_____ DATE PART FAILED
NORTH STAR 1890 WOODLANE DRIVE WOODBURY, MN 55125			NORTH STAR 1890 WOODLANE DRIVE WOODBURY, MN 55125		